

Multi-channel Modular Power System

IT2703 Series User Manual



Model: IT2703

Version: V1.0/06,2024

Notices

© Itech Electronic, Co., Ltd. 2024

No part of this manual may be reproduced in any form or by any means (including electronic storage and retrieval or translation into a foreign language) without prior permission and written consent from Itech Electronic, Co., Ltd. as governed by international copyright laws.

Manual Part Number

IT2702

Revision

1st Edition: March. 8, 2024

Itech Electronic, Co., Ltd.

Trademarks

Pentium is U.S. registered trademarks of Intel Corporation.

Microsoft, Visual Studio, Windows and MS Windows are registered trademarks of Microsoft Corporation in the United States and/or other countries and regions.

Warranty

The materials contained in this document are provided “as is”, and is subject to change, without prior notice, in future editions. Further, to the maximum extent permitted by applicable laws, ITECH disclaims all warrants, either express or implied, with regard to this manual and any information contained herein, including but not limited to the implied warranties of merchantability and fitness for a particular purpose. ITECH shall not be held liable for errors or for incidental or indirect damages in connection with the furnishing, use or application of this document or of any information contained herein. Should ITECH and the user enter into a separate written agreement with warranty terms covering the materials in this document that conflict with these terms, the warranty terms in the separate agreement shall prevail.

Technology Licenses

The hardware and/or software described herein are furnished under a license and may be used or copied only in accordance with the terms of such license.

Restricted Rights Legend

Restricted permissions of the U.S. government. Permissions for software and technical data which are authorized to the U.S. Government only include those for custom provision to end users. ITECH provides this customary commercial license in software and technical data pursuant to FAR 12.211 (Technical Data) and 12.212 (Computer Software) and DFARS 252.227-7015 (Technical Data – Commercial Items) and DFARS 227.7202-3 (Rights in Commercial Computer Software or Computer Software Documentation).

Safety Notices

CAUTION

A CAUTION sign denotes a hazard. It calls attention to an operating procedure or practice that, if not correctly performed or adhered to, could result in damage to the product or loss of important data. Do not proceed beyond a CAUTION sign until the indicated conditions are fully understood and met.

WARNING

A WARNING sign denotes a hazard. It calls attention to an operating procedure or practice that, if not correctly performed or adhered to, could result in personal injury or death. Do not proceed beyond a WARNING sign until the indicated conditions are fully understood and met.



NOTE

A NOTE sign denotes important hint. It calls attention to tips or supplementary information that is essential for users to refer to.

Quality Certification and Assurance

We certify that IT2700 series power supply meets all the published specifications at time of shipment from the factory.

Warranty

ITECH warrants that the product will be free from defects in material and workmanship under normal use for a period of one (1) year from the date of delivery (except those described in the Limitation of Warranty below).

For warranty service or repair, the product must be returned to a service center designated by ITECH.















- The product returned to ITECH for warranty service must be shipped PREPAID. And ITECH will pay for return of the product to customer.
- If the product is returned to ITECH for warranty service from overseas, all the freights, duties and other taxes shall be on the account of customer.

Limitation of Warranty

This Warranty will be rendered invalid if the product is:

- Damaged resulting from customer-wired circuits or customer-supplied parts or accessories;
- Modified or repaired by customer without authorization;
- Damaged resulting from customer-wired circuits or use in an environment not designated by us;
- The product model or serial number is altered, deleted, removed or made illegible by customer;
- Damaged as a result of accidents, including but not limited to lightning, moisture, fire, improper use or negligence.

Safety Symbols

	Direct current		ON (power)
	Alternating current		OFF (power)
	Both direct and alternating current		Power-on state
	Chassis (earth ground) symbol.		Power-off state
	Earth (ground) terminal		Reference terminal
	Caution		Positive terminal
	Warning (refer to this manual for specific Warning or Caution information)		Negative terminal

	A chassis terminal	-	-
---	--------------------	---	---

Safety Precautions

The following safety precautions must be observed during all phases of operation of this instrument. Failure to comply with these precautions or specific warnings elsewhere in this manual will constitute a default under safety standards of design, manufacture and intended use of the instrument. ITECH assumes no liability for the customer's failure to comply with these precautions.

WARNING

- **Do not use the instrument if it is damaged. Before operation, check the casing to see whether it cracks. Do not operate the instrument in the presence of inflammable gasses, vapors or dusts.**
- **The instrument is provided with a power cord during delivery and should be connected to a socket with a protective earth terminal, a junction box or a three-phase distribution box. Before operation, be sure that the instrument is well grounded.**
- **Check all marks on the instrument before connecting the instrument to power supply.**
- **Use electric wires of appropriate load. All loading wires should be capable of bearing maximum short-circuit of electronic load without overheating. If there are multiple loads, each pair of the load power cord must be carry out the full rated short-circuit output current of the power securely.**
- **Ensure the voltage fluctuation of mains supply is less than 10% of the working voltage range in order to reduce risks of fire and electric shock.**
- **Do not install alternative parts on the instrument or perform any unauthorized modification.**
- **Do not use the instrument if the detachable cover is removed or loosen.**
- **To prevent the possibility of accidental injuries, be sure to use the power adapter supplied by the manufacturer only.**
- **We do not accept responsibility for any direct or indirect financial damage or loss of profit that might occur when using the instrument.**
- **This instrument is used for industrial purposes, do not apply this product to IT power supply system.**
- **Never use the instrument with a life-support system or any other equipment subject to safety requirements.**

WARNING

- **SHOCK HAZARD Ground the Instrument.** This product is provided with a protective earth terminal. To minimize shock hazard, the instrument must be connected to the AC mains through a grounded power cable, with the ground wire firmly connected to an electrical ground (safety ground) at the power outlet or distribution box. Any interruption of the protective

(grounding) conductor or disconnection of the protective earth terminal will cause a potential shock hazard that could result in injury or death.

- Before applying power, verify that all safety precautions are taken. All connections must be made with the instrument turned off, and must be performed by qualified personnel who are aware of the hazards involved. Improper actions can cause fatal injury as well as equipment damage.
- **SHOCK HAZARD, LETHAL VOLTAGES** This product can input the dangerous voltage that can cause personal injury, and the operator must always be protected from electric shock. Ensure that the input electrodes are either insulated or covered using the safety covers provided, so that no accidental contact with lethal voltages can occur.
- Never touch cables or connections immediately after turning off the instrument. Verify that there is no dangerous voltage on the electrodes or sense terminals before touching them.

CAUTION

- **Failure to use the instrument as directed by the manufacturer may render its protective features void.**
- **Always clean the casing with a dry cloth. Do not clean the internals.**
- **Make sure the vent hole is always unblocked.**

Environmental Conditions

The instrument is designed for indoor use and an area with low condensation. The table below shows the general environmental requirements for the instrument.



Environmental Conditions	Requirements
Operating temperature	0°C~40°C
Operating humidity	20%~80%(non-condensation)
Storage temperature	-10°C~70 °C
Altitude	Operating up to 2,000 meters
Installation category	II
Pollution degree	Pollution degree 2



Note

To make accurate measurements, allow the instrument to warm up for 30 min.

Regulatory Markings

	<p>The CE mark indicates that the product complies with all the relevant European legal directives. The specific year (if any) affixed refers to the year when the design was approved.</p>
	<p>The instrument complies with the WEEE Directive (2002/96/EC) marking requirement. This affix product label indicates that you must not discard the electrical/electronic product in domestic household waste.</p>

	<p>This symbol indicates the time period during which no hazardous or toxic substances are expected to leak or deteriorate during normal use. The expected useful life of the product is 10 years. The product can be used safely during the 10-year Environment Friendly Use Period (EFUP). Upon expiration of the EFUP, the product must be immediately recycled.</p>
---	--

Waste Electrical and Electronic Equipment (WEEE) Directive



2002/96/EC Waste Electrical and Electronic Equipment (WEEE) Directive

This product complies with the WEEE Directive (2002/96/EC) marking requirement. This affix product label indicates that you must not discard the electrical/electronic product in domestic household waste.

Product Category

With reference to the equipment classifications described in the Annex 1 of the WEEE Directive, this instrument is classified as a "Monitoring and Control Instrument".

To return this unwanted instrument, contact your nearest ITECH office.

Compliance Information

Complies with the essential requirements of the following applicable European Directives, and carries the CE marking accordingly:

- Electromagnetic Compatibility (EMC) Directive 2014/30/EU
- Low-Voltage Directive (Safety) 2014/35/EU

Conforms with the following product standards:

EMC Standard

IEC 61326-1:2012/ EN 61326-1:2013 ¹²³

Reference Standards

CISPR 11:2009+A1:2010/ EN 55011:2009+A1:2010 (Group 1, Class A)

IEC 61000-4-2:2008/ EN 61000-4-2:2009

IEC 61000-4-3:2006+A1:2007+A2:2010/ EN 61000-4-3:2006+A1:2008+A2:2010

IEC 61000-4-4:2004+A1:2010/ EN 61000-4-4:2004+A1:2010

IEC 61000-4-5:2005/ EN 61000-4-5:2006

IEC 61000-4-6:2008/ EN 61000-4-6:2009

IEC 61000-4-11:2004/ EN 61000-4-11:2004

1. The product is intended for use in non-residential/non-domestic environments. Use of the product in residential/domestic environments may cause electromagnetic interference.
2. Connection of the instrument to a test object may produce radiations beyond the specified limit.
3. Use high-performance shielded interface cable to ensure conformity with the EMC standards listed above.

Safety Standard

IEC 61010-1:2010/ EN 61010-1:2010

Content

Quality Certification and Assurance	i
Warranty	i
Limitation of Warranty	i
Safety Symbols	i
Safety Precautions.....	ii
Environmental Conditions.....	iii
Regulatory Markings	iii
Waste Electrical and Electronic Equipment (WEEE) Directive	iv
Compliance Information	v
Chapter1 Quick Reference	9
1.1 Brief Introduction	9
1.2 Front Panel Introduction	10
1.3 Rear Panel Introduction	11
1.4 Meter View.....	11
1.5 View Instrument Identification	13
Chapter2 Inspection and Installation	14
2.1 Unpacking and Transportation	14
2.2 Verifying the Shipment.....	15
2.3 Instrument Size Introduction	16
2.4 Installing the Instrument.....	17
2.4.1 Power Module Installation	17
2.4.2 Rack Mounting	20
2.5 Connecting the Power Cord	22
2.6 Connecting Test Lines (Optional).....	23
2.7 Remote Control	25
2.7.1 USB Interface.....	25
2.7.2 LAN Interface.....	26
2.7.3 CAN Interface	27
Chapter3 Getting Start.....	29
3.1 Power-on the Instrument.....	29
3.2 Main interface overview	30
3.3 Introduction to Interface Symbols.....	32
3.4 Set Parameters	33
3.5 Push-on Knob	33
3.6 Output On/Off Control	34
Chapter4 Power Supply Function	35
4.1 Select the Output Mode.....	35
4.2 Set the Power Output Parameters	35
4.3 Config Menu Introduction.....	35
4.3.1 Rise/fall slope Setting.....	37
4.3.2 Voltage/current/power upper and lower limit settings	37
4.3.3 Set the Internal Resistance	37
4.3.4 CR Function in Sink Mode (Only Bidirectional DC Source)	38
4.3.5 Adjustment of loop speed	38
4.3.6 Setting the isolation function for OFF state	38
4.4 Protection Function for Power Supply	38
4.4.1 Set Over-Voltage Protection (OVP).....	39
4.4.2 Set Over-Current Protection (OCP)	40
4.4.3 Set Over-Power Protection (OPP)	40
4.4.4 Set Under-Current Protection (UCP).....	41
4.4.5 Set Under-Voltage Protection (UVP)	41
4.4.6 Over-Temperature Protection (OTP).....	42

Chapter5	Load Function.....	43
5.1	Load Input Mode.....	43
5.2	Set the Load Input Parameters.....	47
5.3	Set the Power Output Parameters.....	47
5.4	Config Menu.....	48
5.4.1	Rise/fall slope Setting.....	49
5.4.2	Under Voltage Inhibit.....	49
5.4.3	Short-circuit Analog Function.....	50
5.5	Protection Function.....	50
5.5.1	Over-Current Protection (OCP).....	50
5.5.2	Set Over-Power Protection (OPP).....	51
Chapter6	Generating Arbitrary Waveforms.....	52
6.1	LIST.....	52
6.1.1	Run List.....	52
6.1.2	Create a new List file.....	52
6.2	Generating Arbitrary Waveforms (Arb).....	53
6.2.1	Run the Arb Waveform.....	54
6.2.2	Setting the Arb Waveform Common Parameters.....	54
6.2.3	Configuring Sine Arbs.....	54
6.2.4	Configuring Step Arbs.....	55
6.2.5	Configuring Pulse Arbs.....	56
6.2.6	Configuring Ramp Arbs.....	57
6.2.7	Configuring Trapezoid Arbs.....	58
6.2.8	Configuring Staircase Arbs.....	59
6.2.9	Configuring Exponential Arbs.....	60
6.2.10	Configuring User-Defined Arbs.....	61
6.3	Configuring an Arb Sequence (Arb Sequence).....	62
6.4	Configuring Constant-Dwell Arbs.....	63
6.5	Sine Sweep Waveform.....	64
6.6	Battery Simulation Function.....	65
6.7	Battery Charging Test Function.....	66
6.8	Battery Discharging Test Function.....	68
Chapter7	System-Related Functions.....	71
7.1	Setting System General Parameters.....	71
7.2	Setting Instrument General Function.....	71
7.3	Screen Lock Function.....	72
7.4	Switching Local/Remote Mode.....	72
7.5	Timing Output Function.....	73
7.6	Channel Synchronized Output Function.....	73
7.7	Remote Measurement Function.....	74
7.8	Save and Recall Operations.....	74
7.9	Screen Capture Function.....	75
7.10	Query the System Log.....	75
7.11	Query the System Information.....	75
7.12	System Management Functions.....	75
7.13	Digital I/O Function.....	75
Chapter8	Technical Specifications.....	79
8.1	Supplemental characteristics.....	79
8.2	Main technical parameters.....	79
	<i>IT2703 Main frame specifications.....</i>	<i>79</i>
	<i>IT27134R.....</i>	<i>80</i>
	<i>IT27135R.....</i>	<i>81</i>
	<i>IT27137R.....</i>	<i>83</i>
	<i>IT27154R.....</i>	<i>85</i>
	<i>IT27155R.....</i>	<i>87</i>

<i>IT27157R</i>	89
<i>IT27334R</i>	90
<i>IT27335R</i>	92
<i>IT27337R</i>	95
<i>IT27354R</i>	97
<i>IT27355R</i>	99
<i>IT27357R</i>	101
<i>IT27534R</i>	103
<i>IT27535R</i>	104
<i>IT27537R</i>	105
<i>IT27554R</i>	107
<i>IT27555R</i>	109
<i>IT27557R</i>	111
Appendix	113
Specifications of Red and Black Test Lines	113

Chapter1 Quick Reference

This chapter introduces the front and rear panels of the IT2703 series multi-channel power system to ensure that you can quickly understand the appearance, structure, and wiring of the power system and other usage functions before operating the power system, which will help you to better use this series of instruments.

1.1 Brief Introduction

IT2703 series multi-channel modular power system brings ultra-high power density. The 1U main frame can include up to 6 modules (200W each) or 3 modules (500W each). The IT2703 main frame can be equipped with bidirectional DC power supplies, DC power supplies or regenerative loads. And the IT2704 main frame can be equipped with regenerative loads. Different modules can be grouped and synchronized. They have built-in LAN, USB, CAN, digital I/O and free PC software. It can be widely used in ATE integration in R&D, design verification and manufacturing of DC-DC, communication power supplies, power component, electronic products, PCBA, battery simulation and test, chips BMS chips etc.

Features

- ATE systems for R&D, design verification and manufacturing
- Compact size: 1U single unit outputs up to 8 channels
- Flexible modular system: mix and match various modules
- 2 frame (1U), 3 module types (DC power supply, bidirectional power supply, regenerative load)
- Free PC software, display 6-channel output
- Support Web control, use common browser to realize all functions
- Support a set of master-slave parallel connection between modules in the same main frame, different main frame do not support master-slave parallel connection.
- Load function: support CC, CV, CP, CR, CC+CV, CR+CV, CP+CV, CC+CR, AUTO,BSIM (battery simulation)
- Power supply function: Supports CV/CC/CP loop and internal resistance setting
- Bidirectional power supply module supports resistance setting in load mode
- All modules are wide-range modules
- Single module voltage up to 150V, current up to 30A, power up to 500W
- Supports synchronous control between different frames, no upper limit of channels
- Rich trigger output and input, support step trigger output, can trigger other modules (acquisition, oscilloscope, data recording, etc.)
- Up to 50kHz external data recording function to improve test efficiency
- Measurement functions: multi-output/single-output display, oscilloscope, data record display, supports average, minimum and maximum values of V/I/P, and calculates P, Ah and Wh for all outputs
- Output functions: list function, arbitrary waveform, swept sine wave,

arbitrary wave sequence, constant dwell arbitrary wave, load transient, battery simulation*1, battery test, OCP and OPP test*2, output on/off serialization, Watchdog, support output coupling

- Full protection: OVP, UVP, OCP, OPP, OTP, UCP, Foldback, supports protection coupling
- Modules has anti-reverse connection function, built-in relay, and supports anti-discharge and anti-surge functions
- AC input: adaptive 100-240 Vac single phase
- Built-in LAN, USB-TMC,USB-VCP, CAN, digital I/O, data import and export by USB and supports SCPI protocol

*1 only available for bidirectional power supply modules only *2 only available for load modules

Models and Options

The IT2703 main frame can be equipped with up to six 200W modules or three 500W modules, which can be bidirectional power supply modules, DC power supplies modules, or regenerative load modules. The detailed model list is shown in the table below.

Voltage	Current	Power	DC power supply	Bidirectional power supply	Regenerative load
30V	15A	200W	IT27134R	IT27334R	IT27534R
	30A	500W	IT27154R	IT27354R	IT27554R
60V	10A	200W	IT27135R	IT27335R	IT27535R
	20A	500W	IT27155R	IT27355R	IT27555R
150V	5A	200W	IT27137R	IT27337R	IT27537R
	10A	500W	IT27157R	IT27357R	IT27557R

1.2 Front Panel Introduction

The front panel of the IT2703 series instrument is shown below.

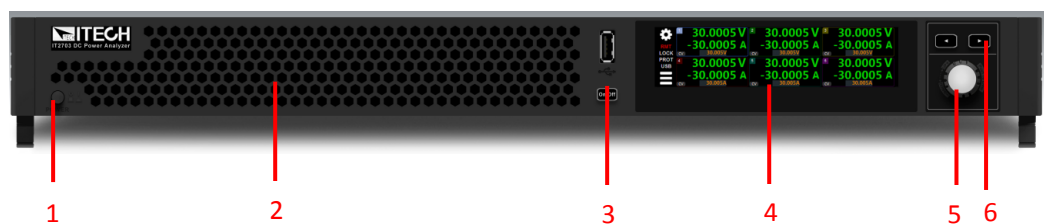

No.	Name	Description
1	Power Switch	Turns the instrument On or Off.
2	Vent hole	Fan Cooling Vents
3	On/Off USB interface	Turn the power supply output on or off. When lit, indicates that the output is enabled or on. USB: Insert a USB disk for exporting data, etc.
4	Display	Displays all instrument functions - information changes based on selected function.
5	push-on knob	The functions of the push-on knob is described as follows.

		<ul style="list-style-type: none"> ● Adjust the value setting ● Select menu item ● Confirm the set value or the selected menu item
6	Left / Right Navigation keys	The left and right navigation keys are used to adjust the cursor to the specified position or scrolls pages to view menu items.

1.3 Rear Panel Introduction

The rear panel of the IT2703 series is shown below.

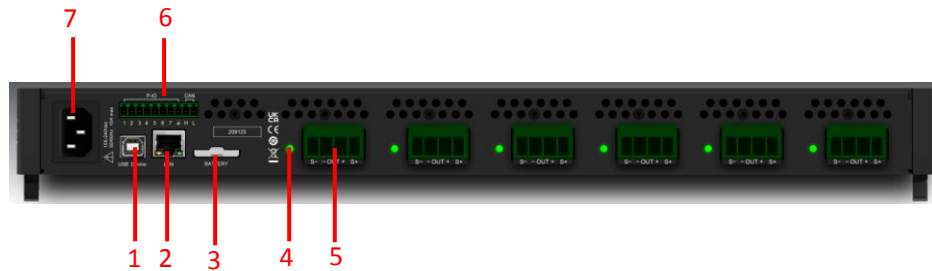

No.	Name	Description
1	USB interface	USB communication interface.
2	LAN interface	LAN communication interface
3	BATTERY	Reserved interface
4	Channel Status indicator	Indicates channel status
5	Output Terminals	Output terminals and remote measurement terminals corresponding to channels.
6	I/O terminals/CAN interface	<ul style="list-style-type: none"> ● Digital Port ● CAN communication interface CAN-H and CAN-L

1.4 Meter View

The display of this model is a touch screen. Pressing the Meter button in the instrument screen enters under Meter View. Users can click the corresponding screen display button to select single channel view and multi-channel view under the meter view.

Single Channel View

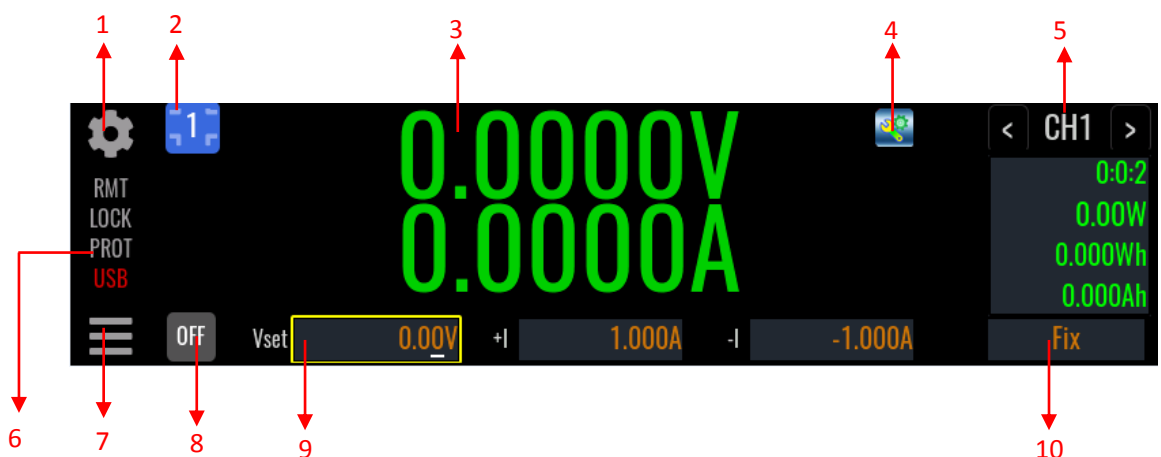

No.	Description
1	Clicking the button opens the channel control panel, which allows you to trigger, clear protection, lock the screen, and control the channel outputs.
2	channel number
3	Voltage, Current, Power
4	Config Menu
5	Present channel number. Press left or right to switch channels
6	Instrument status: remote control, lock screen, protection, USB device
7	Menu icon, click to enter the machine function menu interface
8	Instrument Output Status
9	Voltage and current setting area, different setting parameters in different modes
10	Functional modes of instrument operation

Multiple Channel View



No.	Description
1	Clicking the button opens the channel control panel, which allows you to trigger, clear protection, lock the screen, and control the channel outputs.
2	channel number
3	Voltage, Current, Power
4	Instrument Output Status
5	Channel 2 display area
6	Channel 3 display area

7	Instrument status: remote control, lock screen, protection, USB device
8	Menu icon, click to enter the machine function menu interface
9	Voltage and current setting area, different setting parameters in different modes

1.5 View Instrument Identification

You can quickly view the output ratings, model numbers and options of all power modules installed in your instrument. You can also view the mainframe serial number and firmware revisions. Press the Menu key and then press the Info key. The instrument information window will appear.

	Model	Serial No.	CPU Version	Apfc/Disp Version
	IT27XX	123456789123456789	000.000.194-1.23	1.02/0
Info	1 IT27357	Bidirectional DC Source	150V-10A-500W	0.11-1.04-1.28
	2 No Module			
	3 IT27355	Bidirectional DC Source	60V-20A-500W	0.11-1.04-1.28
	4 IT27554	DC Regenerative Load	30V-30A-500W	0.11-1.04-1.28

The serial numbers of the power modules are located on their respective top covers. Press Meter View to return to the meter view.

Chapter2 Inspection and Installation

2.1 Unpacking and Transportation

Unpacking

For cabinet products, they are packaged in wooden boxes at the factory. After you receive them, please refer to the unpacking instructions provided with the box for disassembly; for products packaged in cartons, please use appropriate tools for unpacking.

It is recommended to keep the complete transport packaging for the lifetime of the device for relocation or return to the manufacture for repair.

Transportation

If you need to transport non-cabinet products, you must pay attention to the following to ensure the safety of equipment and personnel.

CAUTION

- Before moving, make sure that the cabinet or stand where the equipment will be placed has been fixed and meets the load-bearing conditions to avoid tilting and collapsing, causing personnel to be injured, and equipment broken.
- Due to the weight of the product, transport by hand should be avoided where possible. If unavoidable, carry it with two people and holding the product shell and not external parts (such as handles, electrodes, knobs, etc.).
- When carrying, be prepared to bear the weight to avoid sprains or being crushed by heavy objects.
- Use suitable safety clothing, especially safety shoes, when carrying the equipment, as due to its weight a fall can have serious consequences.

After unpacking the cabinet product, if you need to move it to other places, you must pay attention to the following matters to ensure the safety of equipment and personnel.

CAUTION

- The cabinet product is very heavy. Before moving to another location, confirm whether the ground load is in compliance.
- During the process of moving the cabinet, it is recommended that two or more people cooperate and push it slowly and at a constant speed. If you encounter a pit, you need to pay special attention. It is forbidden to push it quickly, otherwise it will easily cause excessive inertia and cause the casters at the bottom of the cabinet to jam and the cabinet to fall.
- It is not advisable to push down the slope to prevent the cabinet from falling down due to the shift of the center of gravity. It is recommended

to use a forklift or crane to move the cabinet.

- ITECH 27U and 37U cabinets are equipped with hoisting rings as standard on the top. It is recommended to use a crane equipped with a four-leg hoisting belt structure for horizontal hoisting and moving, and ensure that the four hoisting belts are the same length to avoid cabinet skew during movement. As shown below.
- After moving to the destination, please lock the four casters to secure the cabinet.
- The cabinet should be placed on a level ground. It is forbidden to place the cabinet on a sloped ground.

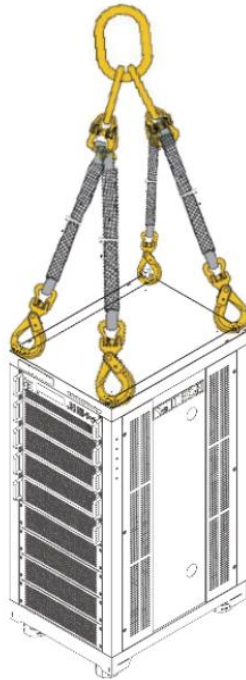

2.2 Verifying the Shipment

Open the package and check the articles within package box before operation. In case of any non-conformity, missing or appearance wearing, please contact ITECH immediately.

The package box should comprise:

Device name	Quantity	Model	Remarks
Multi-channel modular power system	x1	IT2703 series	For the specific models included in this series, refer to 1.1 Brief Introduction.
Power Cord	X1	-	Number of the power cords vary depending on the model, See the Section 2.4 Connecting the Power Cord for power cord connection.
USB cable	x1	-	Used for communicating with the PC.
LAN cable	x1	-	Used for connecting between the instrument.
Calibration Certificate	x1	-	Test report before delivery

**NOTE**

After confirming that package contents are consistent and correct, please appropriately keep package box and related contents. The package requirements should be met when the instrument is returned to factory for repair.

2.3 Instrument Size Introduction

The instrument should be installed at well-ventilated and rational-sized space. Please select appropriate space for installation based on the power supply size.

IT2703

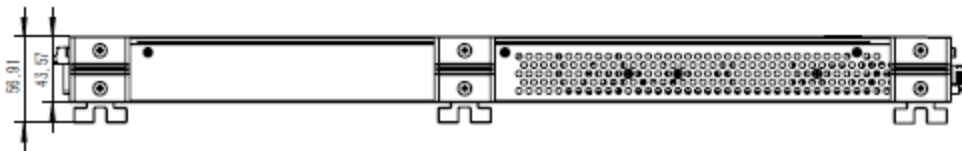
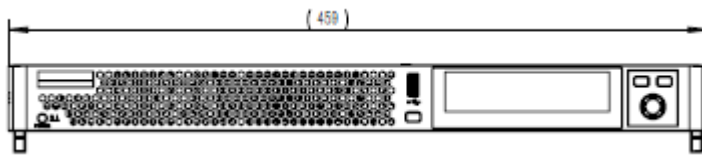
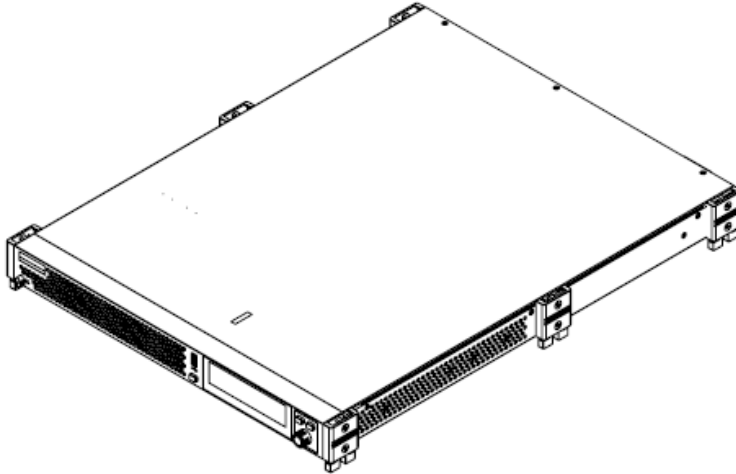

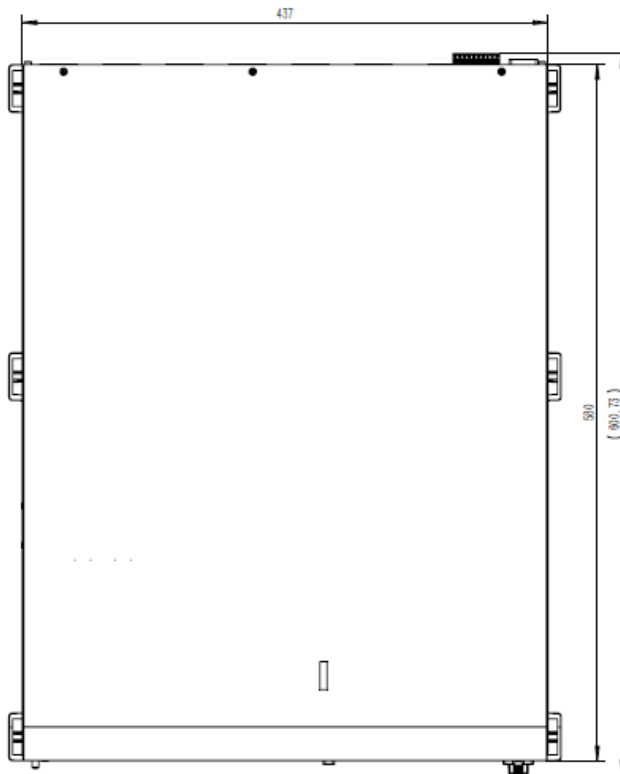

2.4 Installing the Instrument

2.4.1 Power Module Installation

CAUTION

The information in this section applies if you have purchased an IT2700 mainframe without the power modules installed, or if you are adding a power module to the mainframe.

Turn the mainframe off and disconnect the power cord before installing or removing power modules. Observe all standard electrostatic discharge precautions before handling electronic components.

Preparation before installation

The screws used for removing the top cover and mounting the module are M3 type screws, so please prepare the corresponding Phillips screwdriver in advance.

Installation Step

1. Remove the top cover.

Loosen the screws in the locations shown below to remove the top cover.

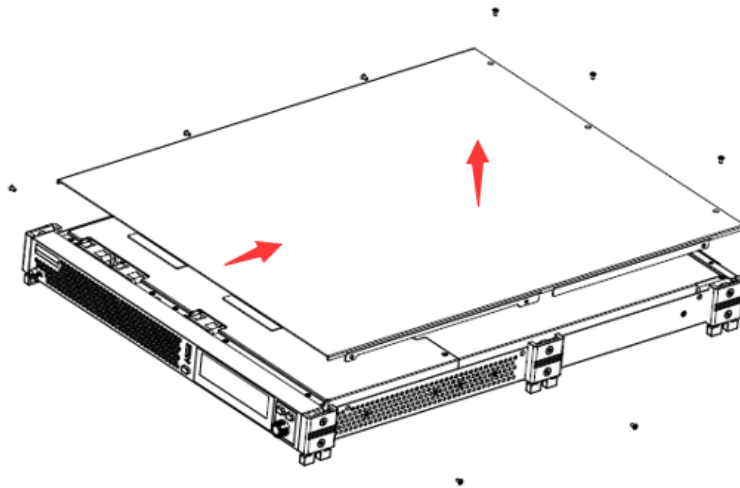
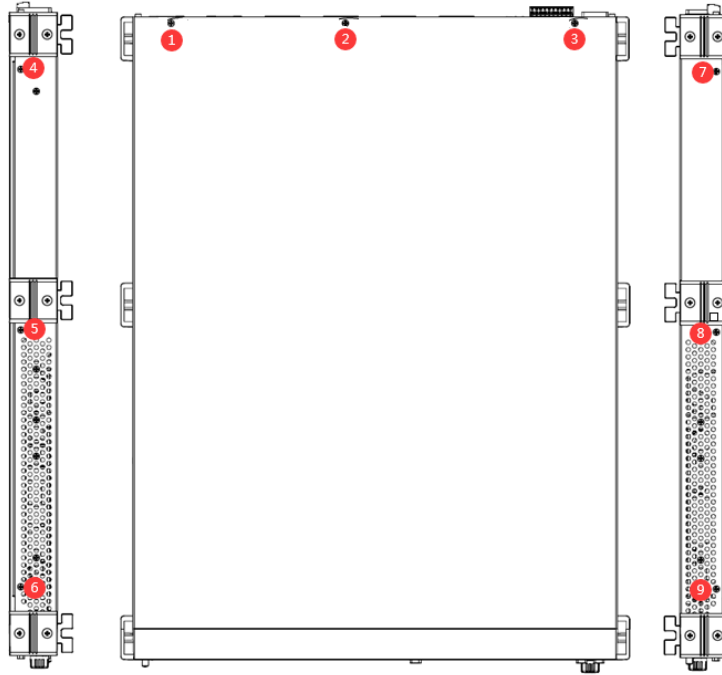

2. Remove the plastic plugs from the terminals corresponding to the module.

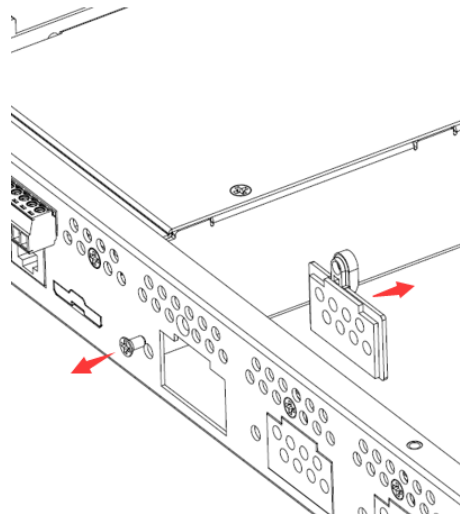

3. Place the power modules into the corresponding slot. (take the 500W

module as an example).

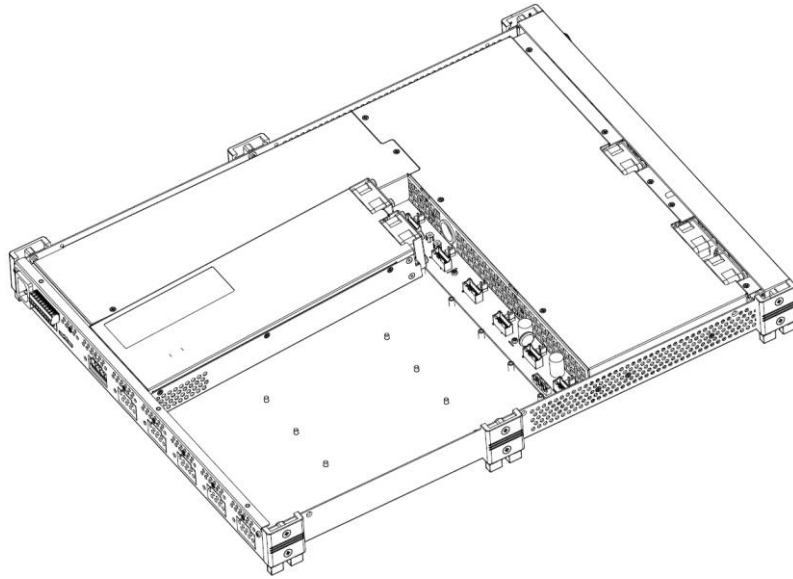

4. Set screws on both ends of the locking module.

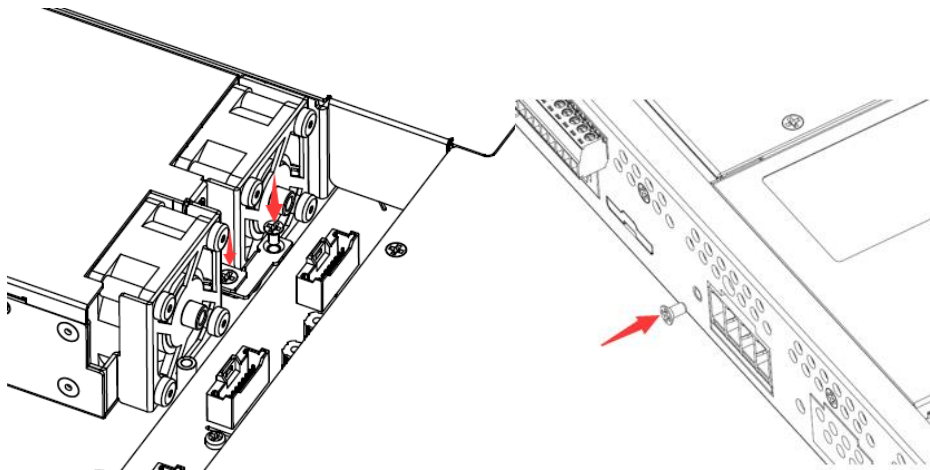

5. Connecting the module wire harness.



The location of the power modules wire harness connection inside the mainframe determines their front panel output and programming channel assignments. For example, modules installed in channel 1 will be connected to

the wire harness for output1 . Modules installed in channel 4 will be connected to the wire harness for output4.

6. Finish the installation. Install the top cover, as shown as below.

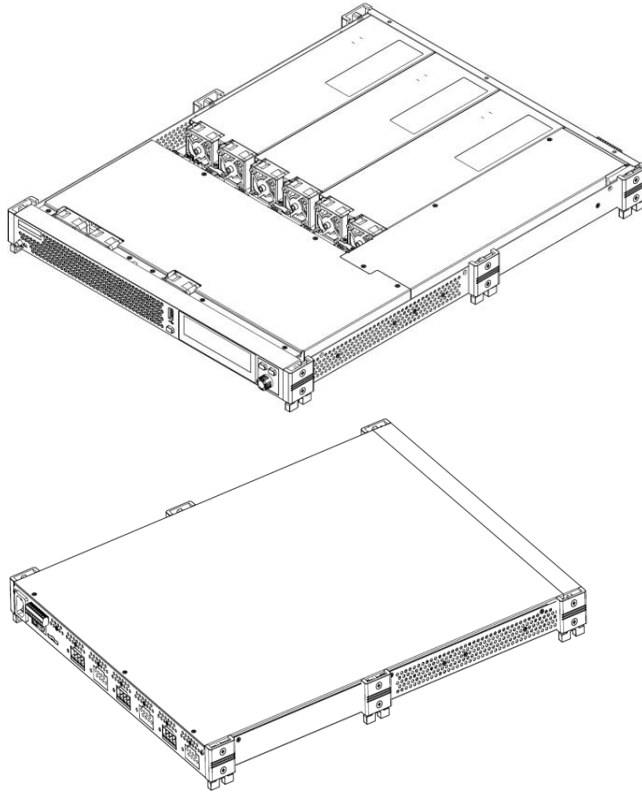

2.4.2 Rack Mounting

Power System can be mounted on a standard 19” rack. ITECH provides user with IT-E157C/IT-E157D mounting rack, as an optional mount kit.

- IT-E157C: Select this kit when the instrument is mounted on the ITECH cabinet.

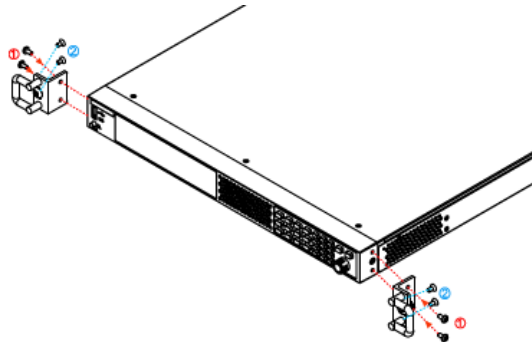

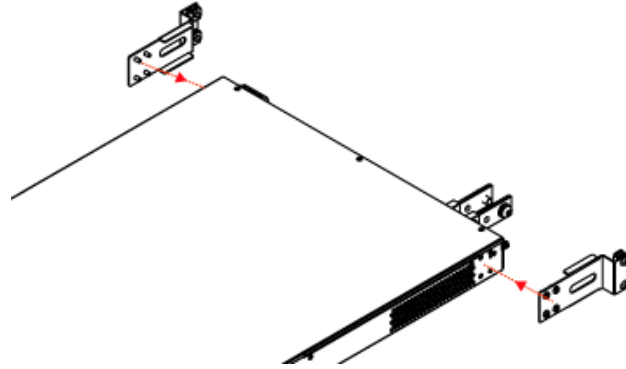

The dimensions of the instrument after installation are shown below.

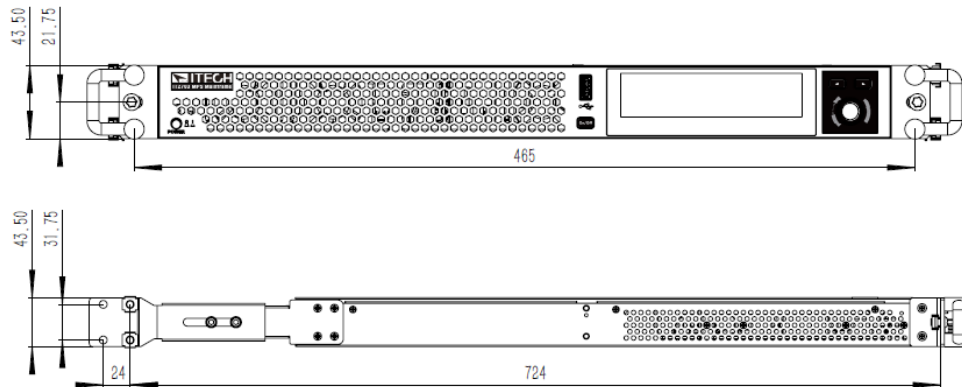

- IT-E157D: Select this kit when the instrument is mounted on another cabinet, this kit can be adjusted to the depth according to the cabinet.

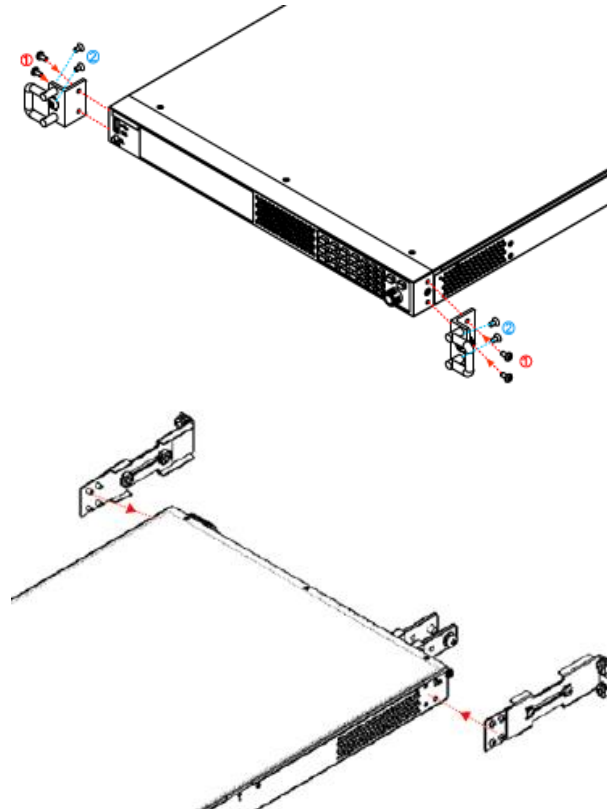

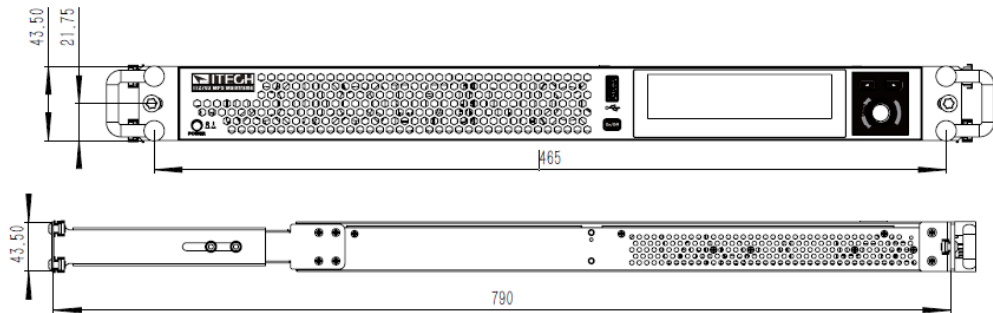

2.5 Connecting the Power Cord

Connect power cord of standard accessories and ensure that the power supply is under normal power supply.

Before connecting the power cord

To prevent electric shock and damage to the instrument, observe the following precautions.

WARNING

- Before connecting power cord, be sure to confirm that the power voltage matches with the rated input voltage of the instrument.
- Before connecting power cord, be sure to switch off the instrument. Verify that there is no dangerous voltage on the connection terminals.
- To avoid fire or electric shock, Make sure to use the power cord supplied by ITECH.
- Be sure to connect the power cord to the AC distribution box with protective grounding. Do not use terminal board without protective grounding.
- Do not use an extended power cord without protective grounding, otherwise the protection function will fail.
- Ensure that the power cord connection terminals are either insulated or covered by the supplied protective cover so that no accidental contact with lethal voltage can occur.

CAUTION

Safety agency requirements dictate that there must be a way to physically disconnect the AC mains cable from the unit. A disconnect device, either a switch or circuit breaker must be provided in the final installation. The disconnect device must be close to the equipment, be easily accessible, and be marked as the disconnect device for this equipment.

Categories of Power Cords

The standard power cord types are as follows. Please select appropriate power cords appropriate to local voltage based on the specifications of power cords below. If purchased model fails to meet local voltage requirements, please contact distributor or factory for change.

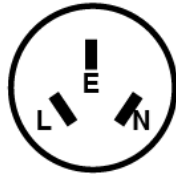

China
IT-E171



United States &
Canada & Japan
IT-E172

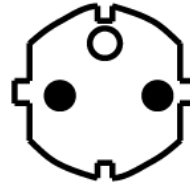

Europe
IT-E173



England
IT-E174

AC Power Input Level

This series power supply comes default with 100Vac-240Vac, 47Hz~63Hz universal input range.

2.6 Connecting Test Lines (Optional)

Test lines are not standard accessories of the instrument. Please select optional red and black test lines for individual sales based on the maximum current value. For specifications of test lines and maximum current values, refer to “**Specifications of Red and Black Test Lines**” in “**Appendix**”.

WARNING

- Before connecting test lines, be sure to switch off the instrument. Power switch is in Off position. Otherwise, contact with output terminals in rear panel may cause electrical shock.
- To avoid electrical shock, before testing, please make sure the rating values of the testing lines, and do not measure the current that higher than the rating value. All test lines shall be capable of withstanding the maximum short circuit output current of the power supply without causing overheat.
- If several loads are provided, each pair of load wires shall safely withstand the rated short circuit output current of the power supply under full load.
- Always use test lines provided by ITECH to connect the equipment. If test lines from other factories are used, please check that the test line can withstand maximum current.

Specification for Test Cables

Test cables are not standard accessories for the instrument. Please select optional red and black test cables for individual sales based on the maximum current value. For specifications of test cables and maximum current values, refer to [A.1 Specifications of Red and Black Test Cables](#) for more information.

Connecting the DUT (Local Measurement)

The instrument supports two kinds of wiring methods with the DUT: local measurement and remote measurement (SENSE). The default test mode is local measurement.

Please confirm that the Remote Sense function in the menu is set to Off, otherwise the instrument will report an error in the present connection mode.

The connection diagram is shown as follow:

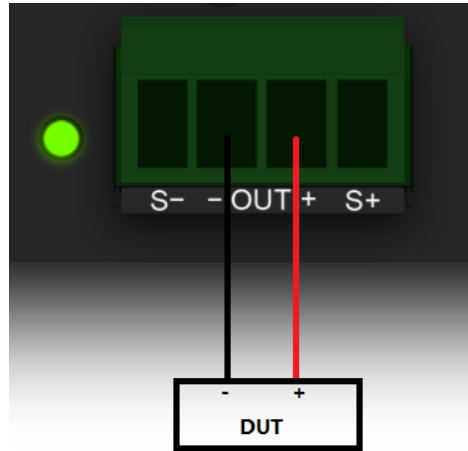

1. Confirm that the power switch is in the OFF position and verify that there is no dangerous voltage on the connection terminals.
2. Remove the output terminals cover of the power system.
3. Loosen the screws of the output terminals and connect the red and black test cables to the output terminals. Re-tighten the screws.

When maximum current that one test cable can withstand fails to meet the rated current, use multiple pieces of red and black test cables. For example, the maximum current is 1,200A, then 4 pieces of 360A red and black cables are required.

4. Thread the red and black test cables through the output terminals cover of the power system and install the cover.
5. (Optional) According to the actual situation of DUT, connect the grounding terminal on the front panel of the instrument to the DUT to ensure the safe grounding.

For the location information, see 1.2 Front Panel Introduction.

6. Connect the other end of the red and black cables to the DUT. The positive and negative poles must be properly connected and fastened when wiring.

Connecting the DUT (Remote Sensing)

Remote measurement is available for the following scenarios:

When the DUT consumes large current or the wires are too long, there is a voltage drop on the wires between DUT and output terminals of the power system.

To maximize measurement accuracy, the power system provides the remote measurement terminals S+ and S- on the rear panel, which can be used to measure the terminal voltage of the DUT.

When the power system is used for battery testing in actual applications, the voltage drop of the wire will lead to voltage inconsistency of both ends and inconsistency of the cutoff voltage of power system and the actual voltage of battery, resulting in inaccurate measurement.

The connection diagram and steps of remote measurement are as follows:

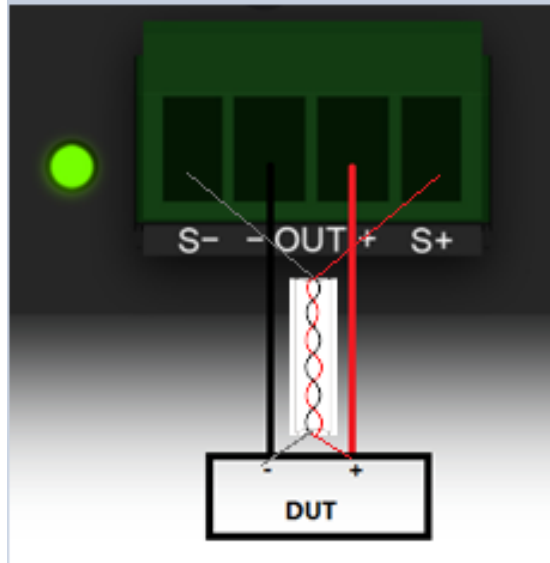

1. Confirm that the power switch is in the OFF position and verify that there is no dangerous voltage on the connection terminals.
2. Remove the output terminals cover of the power system.
3. Refer to the wiring diagram and connect the Vs+ and Vs- with armored twisted-pair cables. Loosen the screws of the output terminals and connect the red and black test cables to the output terminals. Re-tighten the screws.
When maximum current that one test cable can withstand fails to meet the rated current, use multiple pieces of red and black test cables. For example, the maximum current is 1,200A, then 4 pieces of 360A red and black cables are required.
4. Thread the red and black test cables through the output terminals cover of the power system and install the cover.
5. (Optional) According to the actual situation of DUT, connect the grounding terminal on the rear panel of the instrument to the DUT to ensure the safe grounding.
For the location information, see 1.2 Front Panel Introduction.
6. Connect the other end of the remote sense cables to the DUT.
7. Connect the other end of the red and black cables to the DUT. The positive and negative poles must be properly connected and fastened when wiring.
8. Power on the instrument and turn on the Sense function of the instrument.

2.7 Remote Control

This series power system comes standard with three communication interfaces: USB, LAN and CAN, you can choose one of them to communicate with your computer.

2.7.1 USB Interface

Use cables with both USB ends to connect with IT7800 and PC. All functions are programmable over the USB.

The USB488 interface capabilities are described below:

- The interface is 488.2 USB488 interface.
- The interface accepts REN_CONTROL, GO_TO_LOCAL, and LOCAL_LOCKOUT requests.
- The interface accepts MsgID = TRIGGER USBTMC command message and forwards TRIGGER requests to the function layer.

The USB488 device functions are described below:

- The device understands all mandatory SCPI commands.
- The device is SR1 capable.
- The device is RL1 capable.
- The device is DT1 capable.

2.7.2 LAN Interface

When the user connect PC through LAN interface, the following is required to use the LAN interface. The LAN interface complies with the LXI standard.

Under the web control mode, the instrument and computer must communicate through the LAN interface. The default IP address is **192.168.200.100** for the first time, users can use the default IP address.

Connect Interface

Connect the LAN interface of power supply to the computer with a reticle. The gateway address should be consistent with that of the PC, and the IP address should be at the same network segment with the PC's IP address.

For the first time, it is recommended that you first use USB communication to modify the IP address of the instrument by sending commands. You can also directly modify the IP address of your computer and the same network segment of the instrument.

Using Web Server

The instrument has a built-in Web server for monitoring and controlling the instrument through a Web browser in PC.

To use the Web server, connect the instrument and PC over LAN interface and enter the instrument's IP address into the address bar at the top of your PC's Web browser, you can access the front panel control functions including the LAN configuration parameters.

1. The format of the address entered in the address bar of the browser is **http://192.168.200.100**. The specific IP address is subject to the actual instrument settings. The initial IP address is 192.168.200.100. If the IP address has been changed before, you can reset it by pressing the **LAN-Reset** button on the rear panel.

The opened page is displayed as follows:



You can select different pages by clicking the buttons shown in the navigation bar on the left side of the window. The detailed descriptions are as follows.

- Home: Web home interface, displays the model and appearance of the instrument;
- Information: Displays the serial number of the instrument and more system information as well as LAN configuration parameters;
- Web Control: Enables the Web control to begin controlling the instrument. This page allows you to monitor and control the instrument; For a detailed description of control operations, refer to the corresponding manual *IT2700 Web Control Manual*.
- LAN Configuration: Reconfigure the LAN parameters;
- Manual: Go to the ITECH official website and view or download the relevant documents.
- Upload: Performs a system upgrade.

Click **CONNECT** to connect the PC with the instrument, then click

Select File to select the system upgrade installation package (for example, IT2700-U-V000.001.029all.itech), and then click **UPLOAD** performs the upgrade operation. After the upgrade is complete, the instrument needs to be restarted.

2.7.3 CAN Interface

The CAN interface is located on the rear panel of the instrument and is connected to the computer using a CAN communication cable.

Definition of CAN Pins

The definition of CAN pins are as follows.

Pins	Description
H	CAN_H
L	CAN_L

CAN Troubleshooting

If you meet some problems when communicating with PC by CAN interface, please check the following items:

- PC and the instrument must have the same baud rate.
- Ensure you have used the correct communication cable (CAN_H, CAN_L). Please pay attention that some cable may not have a correct internal wiring even it is with an appropriate plug.
- The interface cable is correctly connected (CAN_H to CAN_H, CAN_L to CAN_L).
- If the communication signal is poor or unstable, it is recommended to connect a 120 Ω terminating resistance.

– The connection diagram of a single device is as below.

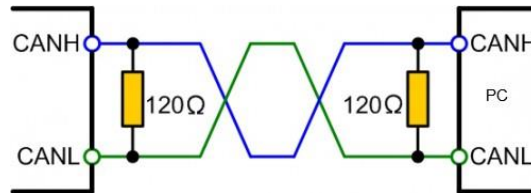

– The connection diagram of multiple devices is as below.

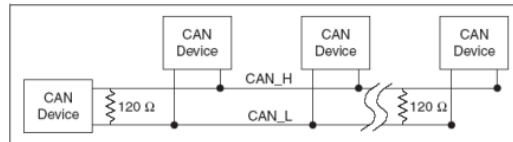

Chapter3 Getting Start

3.1 Power-on the Instrument

A successful selftest indicates that the purchased power product meets delivery standards and is available for normal usage.

Before operation, please confirm that you have fully understood the safety instructions.

Precautions

To prevent electric shock and damage to the instrument, please observe the following precautions.

WARNING

- Before connecting power cord, be sure to confirm that the power voltage matches with the supply voltage.
- Before connecting power cord, be sure to switch off the instrument. Verify that there is no dangerous voltage on the terminals before touching them.
- To avoid fire or electric shock, make sure to use the power cord supplied by ITECH.
- Be sure to connect the main power socket to the power outlet with protective grounding. Do not use terminal board without protective grounding.
- Do not use an extended power cord without protective grounding, otherwise the protection function will fail.
- Ensure that the input electrodes are either insulated or covered using the safety covers provided, so that no accidental contact with lethal voltages can occur.
- If you notice strange sounds, unusual odors, fire, or smoke around or from inside the instrument, flip the POWER switch to the (O) side to turn the instrument off, or remove the power cord plug from the outlet. The detachable power cord may be used as an emergency disconnecting device. Removing the power cord will disconnect AC input power to the unit.

CAUTION

Safety agency requirements dictate that there must be a way to physically disconnect the AC mains cable from the unit. A disconnect device, either a switch or circuit breaker must be provided in the final installation. The disconnect device must be close to the equipment, be easily accessible, and be marked as the disconnect device for this equipment.

Power Switch Introduction

User can press the power switch of IT2700 series instrument directly to turn on or turn off the instrument.

The status of Power switch is as follows.

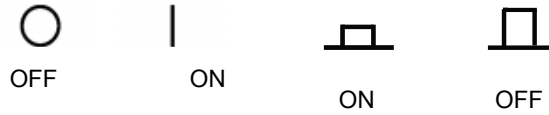

Turning the POWER Switch On

Check that the power cord is connected properly.

Flip the POWER switch to the () side to turn the instrument on. The front panel

display will light up after a few seconds. The indicator corresponding to the channel will blink.

Turning the POWER Switch Off

Flip the POWER switch to the () side to turn the instrument off.

After you turn the POWER switch off, wait at least 10 seconds after the fan stops before you turn the POWER switch back on.

3.2 Main interface overview



The IT2703 series power analyzers are touch screen, users can select and set parameters by hand touch.

This instrument can be inserted into different modules, up to 6 channels, different channels display different number of channels, the instrument presents different interfaces, please refer to the specific module shall prevail.

Power Mode Main Screen

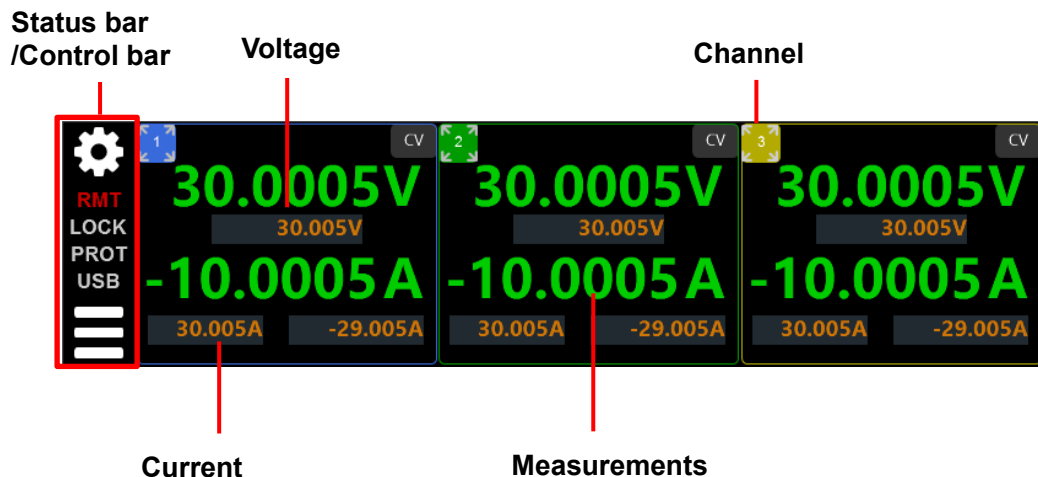
The IT2703 series 3-channel power module main interface is shown below (with power mode CV priority as an example).



Name	Description
Status bar	Displays the status of the instrument, when the indicator shows red it means that it is currently in the current state: <ul style="list-style-type: none"> ● RMT: Remote control ● LOCK: The instrument is in a locked state ● PROT: The instrument is in a protected state ● USB: Discover U disk
Control Bar	<ul style="list-style-type: none"> ● click the setup icon , the interface displays the channel control window, which allows the user to turn on and off the output status. ● click the menu icon , the interface displays the menu window, The user can select all functions and enter the run screen.
Voltage setting	Under the CV priority mode, set the Voltage value, and under the CC priority mode, set the VH and VL values.
Current setting	Under the CV priority mode, set the +I and -I values, and under the CC priority mode, set the current value.
Channel Number	Channel number
measurements	Real meter values.

Menu Interface

click the menu icon , enter the menu interface. This interface contains all the function icons, touch and click on the icons directly or select them by arrow keys or knobs to enter the corresponding function setting page.

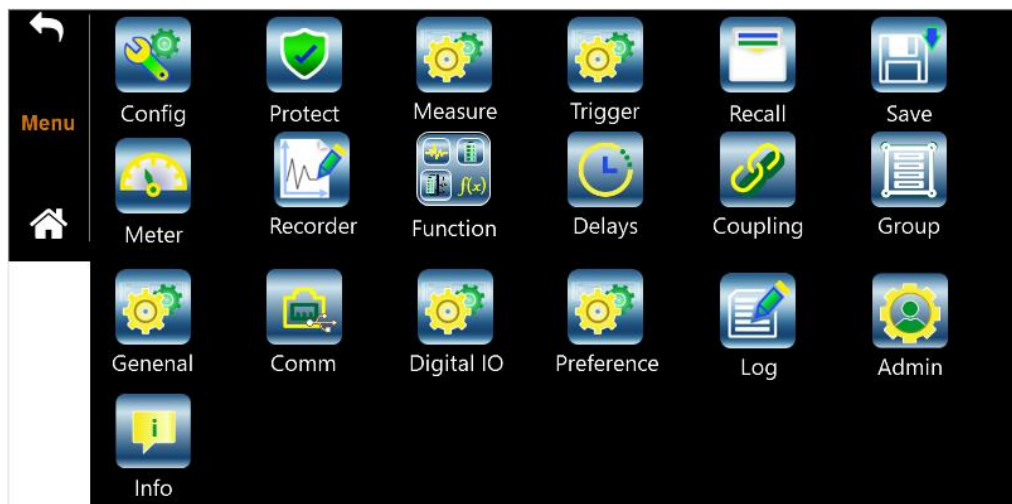





































Name	Description
Config	In configuration menu, you can set the current output parameters, operation mode, slope, power supply internal resistance value, etc. Different modules have different functions and set different parameters, subject to the actual situation.
Protect	Setting instrument protection-related parameters,

	including OCP/OVP/OPP/UCP/UVP.
Measure	Set the function items to be measured, including remote range, peak measurement, and power measurement.
Trigger	Set the trigger source.
Recall	recall the stored system parameter settings.
Save	Saves the system parameter settings to the instrument memory location.
Meter	Enter to meter interface
Recorder	Enter to data recorder interface.
Function	Enter to advanced function interface.
Delays	Output on and off delay settings between channels.
Coupling	Function linkage settings between functions.
Group	Enter the parallel setting interface.
General	Enter the instrument general setting interface.
Comm	Enter the communication setting screen.
Digital IO	Enter the Digital IO function setting interface.
Preference	Enter the setting interface related to the instrument display.
Log	Enter the system log interface.
Admin	Entering the system admin interface.
Info	View information, including instrument SN, firmware version, and information on all modules.

3.3 Introduction to Interface Symbols

The interface of IT2700 power supply will display the following symbols. All the symbols and description are listed in the table below.

Symbol	Function description	Symbol	Function description
	Output is on		Output is off
	Fast speed		Low speed
	Medium speed		CR mode
	CV mode		CP mode
	CC mode		Battery mode
	Reverse positive and negative terminals		Record log
	LIST is running		LIST is finished
	LIST function is waiting for trigger		Sweep function is waiting for trigger
	Sweep running indicator		ARB function is waiting for trigger
	ARB is finished		ARB is running

Symbol	Function description	Symbol	Function description
	ARB is stop		Over current protection
	Sense measure		Sense Error
	Peak OVP		Output inhibit
	Over voltage protection		OTP protection
	Peak OCP		OPP protection
	Under voltage protection		Under current protection
	Click to collapse the present screen		Command error
	Tip image is collapsed, click to expand all icons		Device Calibration Mode

3.4 Set Parameters

The voltage value and current value can be programmed, which can be set to different parameters within the specification range based on customer requirements. This can meet various test requirements of the customer.

After the user presses the Voltage or Current setting on the front panel, the cursor flashes for prompt. The user can use the following methods to set the values.

- Directly use the virtual keyboard to set the value.
- Rotate the knob to set the data in the cursor position. Rotate the knob lockwise to increase the set value and anticlockwise to decrease the set value. Once the data in the cursor position increases to ten, the value will add one to the front position automatically. and once the data in the cursor position decreases to zero, the value will minus one from the front position automatically. This provides convenience for the user to set. The knob can works with the left or right keys. Use the left or right keys to move the cursor position.

NOTE

After entering the menu interface, the knob can also be used to scroll pages to view menu items.

3.5 Push-on Knob

The IT7900P series Power Supply provides a knob on the front panel as shown in the next figure.



The functions of the push-on knob is described as follows.

- Adjust the value setting
- Select menu item
- Confirm the set value or the selected menu item

Adjust the Value Setting

In the value setting interface, rotate the knob clockwise to increase the set value and anticlockwise to decrease the set value.

Select Menu Item

The knob can also be used to view menu items. In the menu item display interface, turning the knob clockwise indicates that the next menu item is selected, and turning the knob anticlockwise indicates that the previous menu item is selected.

Confirm settings

After completing the value setting or selecting a menu item, pushing the knob acts like pressing **[Enter]** key to confirm the operation.

3.6 Output On/Off Control

WARNING

- The **[On/Off]** key is used to turn the output on or off under normal circumstances. Even if the instrument is in control by PC or the keyboard is locked, the **[On/Off]** is still valid.
- The **[On/Off]** key light is off and turning the output off does not place the instrument in a safe state. Hazardous voltages may be present on all output and guard terminals. Putting the equipment into an output-off state does not guarantee that the outputs are powered off if a hardware or software fault occurs. See the cautions about connecting the test lines before connecting test lines.

You can press the **[On/Off]** key on the front panel to control the output status of the power supply. If the **[On/Off]** key light is on, indicates that the output is turned on. The VFD displays the meter value such as voltage, current, power and so on. If the **[On/Off]** key light is off, indicates that the output is turned off. The VFD displays that the power supply state is OFF.

Chapter4 Power Supply Function

IT2703 series multi-channel modular power system can realize different functions by installing different modules, the multi-channel module can be a power module or a load module, this chapter introduces the functions that can be realized by matching the power module.

4.1 Select the Output Mode

When used as a power supply, the operation mode can be selected as CV Priority Mode and CC Priority Mode, and the user can select it in the Config menu.

CV Priority

In CV Priority mode, the output is controlled by a constant voltage feedback loop, the output voltage should be set to the desired value. In addition, positive and negative current limit values should be set.

The CV mode maintains the output voltage at its programmed setting as long as the load current remains within the positive or negative current limit settings.

CC Priority

In current priority mode, the output current should be programmed to the desired positive or negative value. A positive voltage limit value should also be set. The voltage limit should always be set higher than the actual output voltage requirement of the external load. With tracking enabled, the negative voltage limit tracks the positive voltage limit setting. With tracking disabled, you can set different values for the positive and negative voltage limits.

4.2 Set the Power Output Parameters

Power output parameters can be set directly in the Meter interface or in the Config menu.

In CV Priority mode, you can set the output voltage as well as the upper and lower current limit ranges, with +I represents the upper current limit and -I represents the lower current limit. In the voltage setting area, use the virtual numeric keys or the adjustment knob to set the voltage value, and press the knob to make this value effective.

In CC priority mode, you can set the output current as well as the upper and lower limit range of the voltage, VH represents the upper voltage limit and VL represents the lower voltage limit. In the current setting area, use the virtual numeric keys or the adjustment knob to input the current value, and press the knob to make this value effective.

4.3 Config Menu Introduction

When the IT2700 Series multi-channel modular power system is installed with a power supply module, the Config menu is entered as shown in the following table.

Click the button  at the upper right corner of the interface or click Config in the Menu interface to enter the menu setting interface, in which you can set

the electrical performance parameters, sampling-related settings and trigger settings.

Priority	CC/CV priority mode setting	
	CV	Constant voltage loop priority mode
	CC	Constant current loop priority mode
Voltage/Current	Voltage/current setting, Varies depending on the Priority selected.	
Slew Setting	Voltage rise and fall slope setting	
	MAX/Voltage Rise	Voltage rise slope setting, checking the checkbox in front of MAX means that the slope is set to maximum. (Displayed when Priority is selected as CV)
	MAX/Voltage Fall	Voltage fall slope setting, checking the checkbox in front of MAX means that the slope is set to maximum. (Displayed when Priority is selected as CV)
	MAX/Current Rise	Current rise slope setting, checking the checkbox in front of MAX means that the slope is set to maximum. (Displayed when Priority is selected as CC)
	MAX/Current Fall	Current fall slope setting, checking the checkbox in front of MAX means that the slope is set to maximum. (Displayed when Priority is selected as CC)
Tracking Slew	Rising and Falling Slope Tracking, checked to synchronize the setting of the rising and falling slope values.	
Current Setting	When the Priority selection is CV, the current upper and lower limit values are set.	
	+I limit	Positive current upper limit value.
	-I limit	Negative current upper limit value.
	Tracking limits	Upper and Lower Limit Setting Tracking, checked to synchronize the setting of positive and negative upper limit values.
Voltage Setting	When Priority is selected as CC, the voltage upper and lower limit values are set.	
	Voltage High	Voltage upper limit
	Voltage Low	Voltage lower limit
	Tracking limits	Upper and Lower Limit Setting Tracking, checked to synchronize the setting of the upper and lower limit values.
Power Setting	Sets the power limit value.	
	+P limit	Positive power upper limit value.
	-P limit	Negative power upper limit value.

	Tracking limits	Upper and Lower Limit Setting Tracking, checked to synchronize the setting of positive and negative upper limit values.
Internal Resistance	Set the power supply internal resistance value when Priority selection is CV. Clicking the checkbox after Enable indicates that the power supply internal resistance function is turned on.	
Sink Resistance	Set the CR function in sink mode. This parameter needs to be set only when Priority Mode is selected as CC.	
Output Off Return to 0V	On: Indicates that the voltage drops rapidly to 0V when the output is turned off. Off: Indicates that the voltage naturally drops to 0V when the output is turned off.	
Power Relay Lock	On: Indicates that the electrical isolation function is on. Off: Indicates that the electrical isolation function is off.	
Regulation speed	Loop Speed: Low Meduim High	

4.3.1 Rise/fall slope Setting

The Rise/fall slope is the rate at which one value changes to another value, and the rate in source mode can be set to either a slope value or a time value.

The slope setting can be set in the Config menu.

This instrument supports setting the rising and falling slopes in all modes.

The type of slope value can be modified in the system menu in power mode.

1. Click the General icon in the Menu interface to enter the system general configuration interface.
2. Select **“General”** > **“Source Slope Type”**.
 - Time: Indicates that the slope setting value is a time value in s.
 - Slew: Indicates that the slope setting value is the change value per millisecond, and the unit is V/ms or A/ms depending on the mode.

4.3.2 Voltage/current/power upper and lower limit settings

The IT2700 series defaults to CV output mode in power mode. The output voltage and current upper and lower limits can be set directly under the main interface or set in the Config menu.

When the output current exceeds the upper current limit value set by +I, the power supply will switch to the current limit mode and output at the current limit value while decreasing the output voltage.

When the output power exceeds the set power upper limit value, the power supply will switch to the power limit mode and output at the power limit value, while both voltage and current are adjusted.

4.3.3 Set the Internal Resistance

The IT2700 series power supply provides internal resistance setting (CV priority mode only). The procedures are shown as below.

1. Click the Config icon in the Menu interface to enter the configuration interface.

2. Select the **Internal Resistance** item, Check the box front of Enable.
3. setting the value of the internal resistance.

4.3.4 CR Function in Sink Mode (Only Bidirectional DC Source)

This series module supports CR testing in sink mode, and the sink current capability of CR is controlled by the current setting value in CC priority mode. The usage of this function is as follows:

Press [**Config**] to enter the configuration menu interface.

1. Select **Priority** to **CC** mode.
2. Select the Sink Resistance item, and check the box front of Enable.
3. Set the Sink resistance value, the range from 0.03 to 300Ω.

The following takes the setting of 10 Ω as an example to introduce the actual test results.

4. Set the voltage and current.
 - a. Set the current value to 3A in Config interface or meter interface as an example.
 - b. Set the upper voltage limit value V-High=20V and V-Low=0V under Config interface or meter interface.
 - c. Set the DUT (power supply) to output 50V, 10A.

At this time, 10 Ω in sink mode (according to the formula $I=U/R$, sink current is $50 \div 10=5A$), due to the limitation of $I_s = -3A$ in CC priority mode, the actual sink current is 3A, and the instrument is working In CC mode. If **Sink Resistance** is set to 20 Ω, the sink current is 2.5A, which is within the limit of current limit setting, so the instrument works in CR mode at this time.

4.3.5 Adjustment of loop speed

Users can adjust the loop speed according to the DUT to improve the stability of the power supply, when the DUT is a capacitive or inductive load, select “Low”, when the connected load is a resistor, select “High”.

4.3.6 Setting the isolation function for OFF state

This item is used to set the connection status after the power supply output is off. When the Relay option is set to On, a relay is used to disconnect the internal circuits and external loads after the power supply outputs Off.

4.4 Protection Function for Power Supply

The IT2700 series power supply provides the general protection functions such as overvoltage, overcurrent, overpower, undercurrent, undervoltage protection, foldback protection and over temperature. The corresponding protection parameters can be configured in the Protect menu.

The descriptions of Protect menu are listed in the table below.

Over Voltage	OVP	
	OVP State	OVP status
	Voltage	OVP protection level
	Delay	Protection delay, range: 0.001s-10s
Over Current	OCP	
	OCP State	OCP status
	±Current	OCP protection level

	Delay	Protection delay, range: 0.001s-10s
Over Power	OPP	
	OPP State	OPP status
	±Power	OPP protection level
	Delay	Protection delay, range: 0.001s-10s
Under Voltage	UVP	
	UVP State	UVP status
	Voltage	UVP protection level
	Warm	Protection warm time, range: 0.001s-30s
	Delay	Protection delay, range: 0.001s-10s
Under Current	UCP	
	UCP State	UCP status
	+Current	UCP protection level
	Warm	Protection warm time, range: 0.001s-30s
	Delay	Protection delay, range: 0.001s-10s
Foldback	Foldback Protection	
	Mode	OFF: indicates that the foldback function is turned off. CV to CCCP: indicates that the instrument triggers protection when the instrument's operation mode is switched from CV to CC and CP mode. CC to CVCP: indicates that the instrument triggers protection when the instrument's operation mode is switched from CC to CV and CP mode.
	Delay	FOLDBACK delay time

4.4.1 Set Over-Voltage Protection (OVP)

Users can enable the OVP function and set the protection level and protection delay time. When the voltage (i.e., the Meter value) is greater than this protection level and the delay time is exceeded, the power supply will enter the OVP state, and output is disabled.

Possible Cause

Many reasons can cause OVP, the details are as follows:

- The set protection limit Level is lower than the voltage Meter value.
- The external (AC input) inputs a higher voltage.
- The power supply outputs a high voltage due to a fault.

WARNING

Please avoid inputting an external voltage higher than 120% rated value, or the instrument will be damaged.

How to Set

The operation steps to set OVP are as follows.

1. Press the **[Protect]** on the menu interface to enter the protection interface.
2. Use the knob or direct touch-click to select OVP (Off), press the on/off box and set it to On.
3. Set the voltage protection point and delay time and confirm by pressing **[Enter]**.

4.4.2 Set Over-Current Protection (OCP)

Users can enable the OCP function and set the protection limit Level and protection delay time **Delay**. When the current (i.e., the Meter value) is greater than this protection limit and the delay time is exceeded, the power supply will enter the OCP state and output is disabled.

Possible Cause

Many reasons can cause OCP, the details are as follows:

- The set protection limit Level is lower than the current Meter value.
- The external (AC input) inputs a higher current.
- The power supply outputs a high current due to a fault.

How to Set

The operation steps to set OCP are as follows.

1. Press the **[Protect]** on the menu interface to enter the protection menu.
2. Use the knob or direct touch-click to select OCP (Off), press the on/off box and set it to On.
3. Set the current protection point and delay time and confirm by pressing **[Enter]**.

For bidirectional power supply, the protection point can be set to a positive or negative value, i.e. OCP protection for output or input current.

4.4.3 Set Over-Power Protection (OPP)

Users can enable the over-power protection function and set an over-power protection point Level and protection delay time Delay, when the power in the circuit (i.e., Meter value) is greater than this protection point, and exceeds the delay, the power supply or load will enter the over-power protection state and output is disabled.

Possible Cause

Many reasons can cause OPP, the details are as follows:

- The set protection limit Level is lower than the power system value.
- The power supply outputs a high power due to a fault.

How to Set

The operation steps to set OPP are as follows.

1. Press the **[Protect]** on the menu interface to enter the protection menu.
2. Use the knob or direct touch-click to select OPP (Off), press the on/off box and set it to On.

3. Set the power protection point and delay time and confirm by pressing **[Enter]**.

For bidirectional power supply, the protection point can be set to a positive or negative value, i.e. OpP protection for output or input power.

4.4.4 Set Under-Current Protection (UCP)

Users can enable the undercurrent protection function and set the instrument warm time, undercurrent protection point and protection delay time, when the current in the circuit (i.e. Meter value) is lower than this protection point and exceeds the delay, the power supply will enter the undercurrent protection state and output is disabled. Within the warm time, the instrument does not detect the undercurrent condition.

Possible Cause

Many reasons can cause UCP, the details are as follows:

- The set protection limit Level is greater than the current Meter value.
- The external (AC input) inputs a lower current.
- The power supply outputs a low current due to a fault.

How to Set

The operation steps to set UCP are as follows.

1. Press the **[Protect]** on the menu interface to enter the protection menu.
2. Use the knob or direct touch-click to select UCP (Off), press the on/off box and set it to On.
3. set the instrument warm time, undercurrent protection point and protection delay time and confirm by pressing **[Enter]**.

For bidirectional power supply, the protection point can be set to a positive or negative value, i.e. UCP protection for output or input current.

4.4.5 Set Under-Voltage Protection (UVP)

Users can enable the UVP function and set the instrument warm-up time, protection limit and protection delay time. When the voltage (i.e., the Meter value) is lower than this protection limit and exceeds the delay, the power supply will enter the undervoltage protection state and output is disabled. Within the warm time, the instrument does not detect the undervoltage condition.

Possible Cause

Many reasons can cause UVP, the details are as follows:

- The set protection limit Level is greater than the voltage Meter value.
- The external (AC input) inputs a lower voltage.
- The power supply outputs a low voltage due to a fault.

How to Set

The operation steps to set UCP are as follows.

1. Press the **[Protect]** on the menu interface to enter the protection menu.
2. Use the knob or direct touch-click to select UVP (Off), press the on/off box and set it to On.

set the instrument warm time, undercurrent protection point and protection delay time and confirm by pressing **[Enter]**.

4.4.6 Over-Temperature Protection (OTP)

When internal temperature of instrument is higher than about 90 ° C, the instrument is under temperature protection. At this time, the instrument will automatically be OFF and VFD status indicator Prot lights up and the screen prompts OTP.

Possible Cause

To prevent damaging heat build-up and ensure specified performance, make sure there is adequate ventilation and air flow around the instrument to ensure proper cooling. Do not cover the ventilation holes on the rear panel, sides, or bottom of the instrument. Even with proper ventilation, the instrument can overheat in the following situations.

- If the ambient temperature is too high.
- If you use the instrument to test for long periods.

How to Set

The OTP limit does not need to be set, and the internal device of the instrument automatically detects and determines whether to enter the OTP state.

If an over-temperature condition occurs, power off the instrument and allow it to cool for at least 30 minutes. After the internal temperature of the instrument has cooled down, power it on again.

CAUTION

When you return power to the instrument, verify that the cooling fan is running. If not, please contact ITECH Technical Support. Leaving the instrument powered on with an inoperative cooling fan may result in damage to the instrument.

Chapter5 Load Function

IT2703 series multi-channel module system can realize different functions by installing different modules, the multi-channel module can be a power module or a load module, this chapter introduces the functions that can be realized by pairing with a load module.

5.1 Load Input Mode

The operating modes of the IT2703 series instruments in load mode include the following:

Constant Mode

- Constant Current Mode (CC)

In this mode, the electronic load will sink a constant current in accordance with the programmed value regardless of the input voltage. See figure as follow.

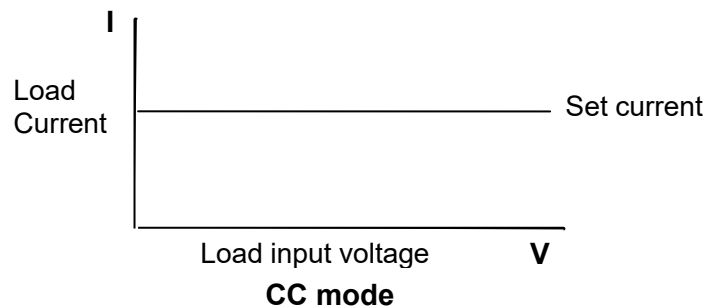

- Constant Resistance Mode (CR)

In this mode, the electronic load was equivalent to a constant resistance, as shown below, the electronic load will linearly change the current according to the input voltage. See figure as follow.

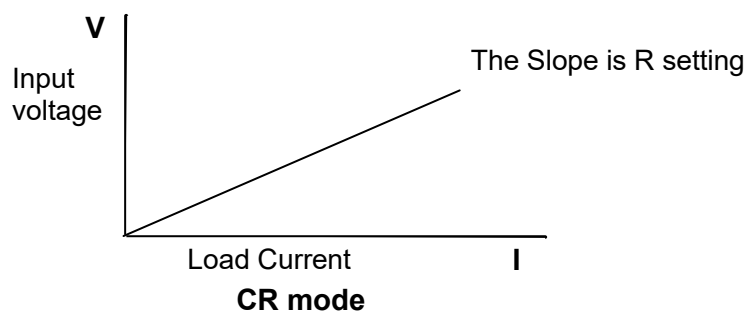

- Constant Voltage Mode (CV)

In this mode, the electronic load will attempt to sink enough current to control the source voltage to the programmed value. See figure as follow.

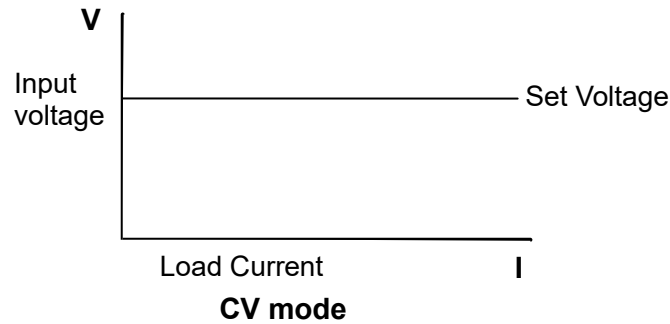

- Constant Power Mode (CP)

In CP mode, the load will consume a constant power. See Figure as follow. If the input voltage rises, the input current will decline. The $P (=V * I)$ will remain on the set power.

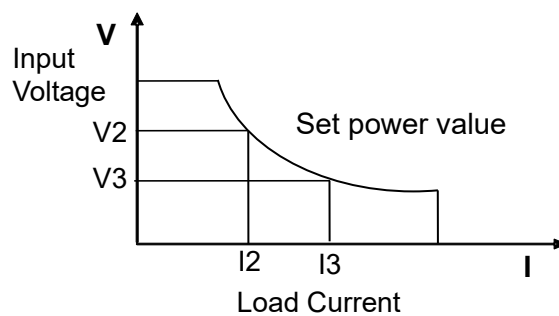

Complex Operation Mode

Complex operating modes include CC+CV, CV+CR, CR+CC, CV+CP and AUTO modes, which can satisfy a wide range of test requirements.

- CC+CV Mode

In CC+CV mode, it has to program the constant voltage and constant current first and then start the UUT for output. When the UUT voltage starts to output, the Load will sink in CV mode according to the programmed voltage. When the voltage rises to exceed the set constant current for sinking, it will switch to CC mode for sinking.

The CC+CV mode can be applied to the load simulation battery and test the charging station or the car charger. When the CV is working, the maximum loading current is limited.

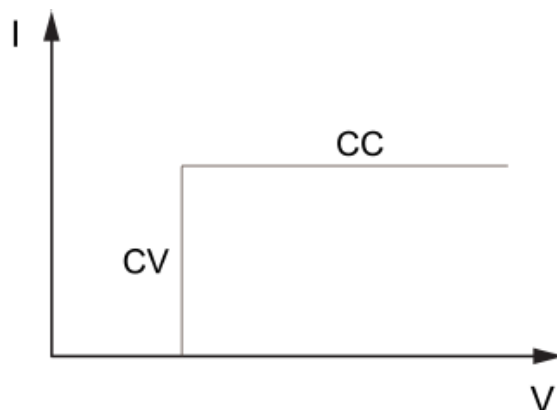

- CR+CV Mode

In CR+CV mode, it has to program the constant voltage and constant resistance first and then start the UUT for output. When the UUT voltage starts to output, the Load will sink in CV mode according to the programmed constant voltage. When the voltage rises to exceed the set constant resistance for sinking, it will switch to CR mode for sinking.

The CR+CV mode can be applied to the LED simulation and test the LED power supply to get the LED current ripple parameters.

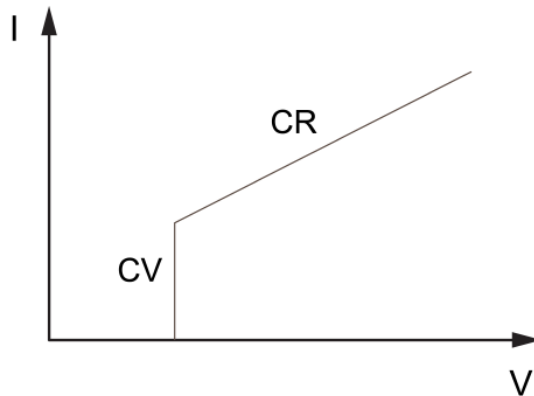

- CC+CR Mode

In CC+CR mode, it has to program the constant resistance and constant current first and then start the UUT for output. When the UUT voltage starts to output, the Load will sink in CR mode according to the programmed resistance. When the voltage rises to exceed the set constant current for sinking, it will switch to CR mode for sinking.

The CC+CR mode is commonly used in the testing of voltage limiting, current limiting characteristics, constant voltage accuracy, and constant current accuracy of on-board chargers, which prevents over-current protection of on-board chargers.

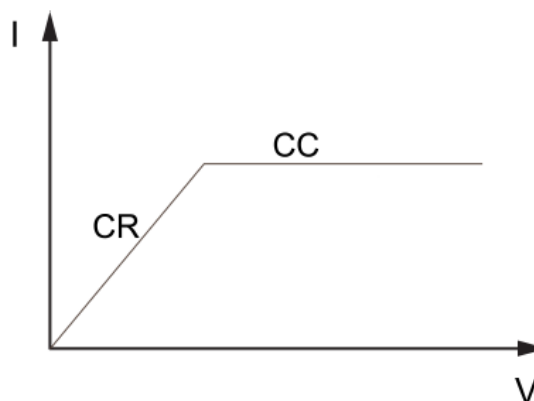

- CP+CV

In CP+CV mode, it has to program the constant power and constant voltage first and then start the UUT for output. When the UUT voltage starts to output, the Load will sink in CV mode according to the programmed voltage. When the voltage rises to exceed the set constant power for sinking, it will switch to CP mode for sinking.

The CP+CV mode is often used to UPS battery test, simulate the current change

when the battery voltage is decaying. It can also be used to simulate the characteristics of the inputs of DC-DC converters and inverters.

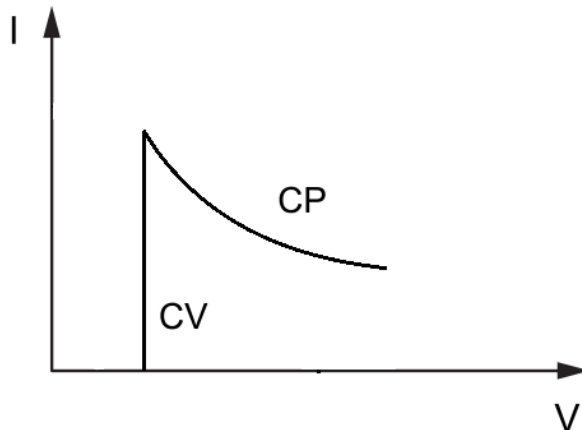

- AUTO (CC+CR+CP+CV)

In Auto mode, it has to program the constant voltage, constant resistance, constant current and constant power, and then start the UUT for output. When the UUT voltage starts to output, the Load will sink according to the programmed constant voltage in CV mode. When the voltage rises, it will automatically switch to CR mode and to the CC mode at last for sinking. It will switch to CP mode for sinking if the UUT outputs high voltage abnormally.

Under this mode, the load can automatically switch among CV, CR, CC and CP modes. It is suitable for lithium ion battery charger testing to get a complete V-I charging curve. Moreover, the auto mode can avoid damaging the UUT when the protection circuit is damaged.

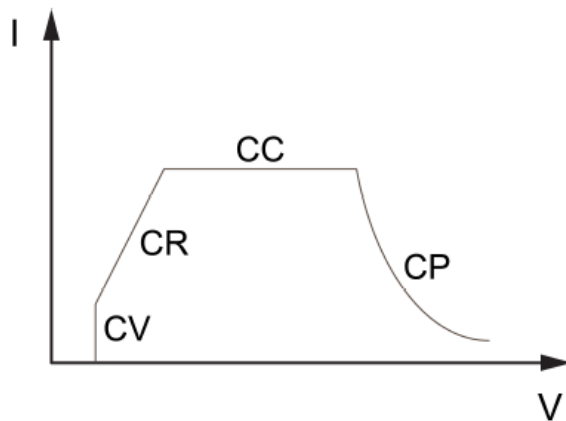

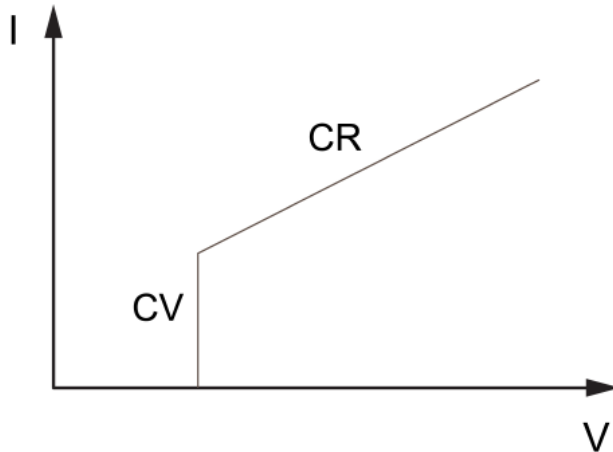

Battery simulation mode (BSIM)

IT2700 series load comes with a battery simulation mode, which is applicable to discharge function test for the charger. The user can directly select this mode in the configuration menu.

In the charging principle of charger, after the charger is connected to the battery, monitor the battery voltage at first. If the battery connection is reliable and correct, the charger enters the charging state. When the instrument is under the battery simulation mode of load, an simulate battery voltage can be set, which has weak output capacity capable of outputting small current for simulating battery state. Thus, the charger's working requirements can be met.

In the configuration menu, if Priority Mode is selected as BSIM, the load enters the battery simulation state. Press return key and return to the main interface. At this moment, the user can set the voltage value V_{set} and the upper limit of input current I_{set} to simulate battery.

When the load is under the battery simulation mode, the loaded current limit is the maximum current value of the model. The user does not need to set small current for output, the output current value has been defined in the instrument.

5.2 Set the Load Input Parameters

Load input parameters can be set directly in the Meter interface or in the Config menu.

you can set the input value by virtual numeric keys or the adjustment knob, and press the Enter key or the knob to make this value effective.

5.3 Set the Power Output Parameters

Power output parameters can be set directly in the Meter interface or in the Config menu.

In CV Priority mode, you can set the output voltage as well as the upper and lower current limit ranges, with +I represents the upper current limit and -I represents the lower current limit. In the voltage setting area, use the virtual numeric keys or the adjustment knob to set the voltage value, and press the knob to make this value effective.

In CC priority mode, you can set the output current as well as the upper and lower limit range of the voltage, V_H represents the upper voltage limit and V_L represents the lower voltage limit. In the current setting area, use the virtual

numeric keys or the adjustment knob to input the current value, and press the knob to make this value effective.

5.4 Config Menu

When the IT2700 Series Multi-Channel Source Load System is installed with a power supply module, the Config menu is entered as shown in the following table.

Click the button at the upper right corner of the interface or click Config in the Menu interface to enter the menu setting interface, in which you can set the electrical performance parameters, sampling-related settings and trigger settings.

Priority	Setting the mode of instrument operation	
	CV	Constant Voltage Mode
	CC	Constant Current Mode
	CR	Constant Resistance Mode
	CP	Constant Power Mode
	CC+CV	CC+CV Mode
	CC+CR	CC+CR Mode
	CR+CV	CR+CV Mode
	CP+CV	CP+CV Mode
	CC+CP+CR+CV(Auto)	CC+CP+CR+CV Mode
Voltage/Current /Resistance/Power	Set the voltage value/current value/resistance value/power value, which varies depending on the selected Priority.	
Slew Setting	Voltage rise and fall slope setting	
	MAX/Voltage Rise MAX/Voltage Fall	Voltage rise/fall slope setting, checking the checkbox before MAX means that the slope is set to maximum. (Displayed when Priority is selected as CV)
	MAX/Current Rise MAX/Current Fall	Current up/down slope setting, checking the checkbox before MAX means that the slope is set to maximum. (Displayed when Priority is selected as CC)
	MAX/Power Rise MAX/Power Fall	Power up/down slope setting, checking the checkbox before MAX means that the slope is set to maximum. (Displayed when Priority is selected as CP)
	MAX/Resistance Rise MAX/Resistance Fall	Resistance up/down slope setting, checking the checkbox before MAX means that the slope is set to maximum. (Displayed when Priority is selected as CR)
Tracking Slew	Rising and Falling Slope Tracking, checked to synchronize the setting of the rising and falling slope values.	
Under Voltage Inhibit	When the undervoltage inhibit function is enabled, the load	

	will not sink current until the input voltage rises above the Voltage on setting.	
	Off	Disable this function
	Live	When the voltage falls below the Voltage On setting, the input is turned off. Turns the input on again when the voltage reaches the Voltage On setting.
	Latching	When the voltage is below the Voltage On setting, the load still sink current.
Voltage On	Voltage on setting. Displayed when Under Voltage Inhibit selects Live or Latching.	
Voltage Off	Displayed when the Under Voltage Inhibit function is set to LIVE mode, sets the voltage value for unloading.	
I limit	The current limit value in voltage priority mode. (Displayed when Priority is selected as CV)	
Enable Short	Short the input terminals. Simulates a short circuit on the load input. Applies to all priority modes.	
Power Relay Lock	On: Indicates that the electrical isolation function is on. Off: Indicates that the electrical isolation function is off.	
Regulation speed	Power loop regulation speed. Low Meduim High	

5.4.1 Rise/fall slope Setting

The Rise/fall slope is the rate at which one value changes to another value.

The slope setting can be set in the Config menu.

This instrument supports setting the rising and falling slopes in all modes.

1. Click the **Config** icon in the Menu interface to enter the configuration interface.

The user can set the rising and falling slopes for voltage, current, resistance and power.

2. Each setting item can be selected by using the right and left arrow keys. Then use the knob to adjust the setting value and press the knob to confirm.

Selecting the Max checkbox directly in front of the slope setting sets the current slope to the maximum value. And select Tracking Slew to set both the upward and downward slopes.

5.4.2 Under Voltage Inhibit

The under voltage inhibit function controls the load sink current state by setting an voltage On value. There are two modes for this function: Live and Latching:

- when Live is selected, it indicates the load sink current state following input voltage, when the voltage falls below the Voltage Off setting, the sink current state is stopped, sink current again when the voltage reaches the Voltage On setting.
- When Latching is selected, it indicates the sink current state is latched, When the input voltage is below the Voltage On setting, the load still sink current.
- If this function is not enabled, then you can select Off to turn off the under

voltage inhibit function.

When testing some power products with slow voltage rise speed, if the electronic load input is opened before power, A protection occurs in the power supply. In this way, the user may set Voltage on value. The electronic load only sink current when power voltage is higher than this value.

Please confirm whether it is necessary to set voltage on setting value, a step that provides convenience for limiting working voltage value. If not necessary, do not set the Under voltage inhibit to prevent unnecessary trouble from failure of loading.

If the instrument cannot load, please firstly check whether the Under voltage inhibit function is set.

5.4.3 Short-circuit Analog Function

The IT2700 series load can simulate a short circuit at the input. Under panel operation, you can enter the **Config** menu and check **Enable short** to enable the short circuit state. The short circuit mode does not affect the current setting value, and when Enable short is unchecked, the load returns to the original setting state.

In the short circuit mode, the current value is determined by the operation mode and the current range. Under CC, CW and CR modes, maximum short-circuit current is 110% of the current range. Under CV mode, short-circuit current equals to current when constant voltage is 0V.

5.5 Protection Function

The IT2700 series multichannel source-load system has different protection menus when using different modules. The following describes the protection functions in the power mode and the protection functions in the load mode.

Click Protect function in Menu to enter Protect Configuration menu page, the menu list and introduction of Protect function are shown below.

Over Current	Over current protection	
	OCP State	OCP state: on/off
	Current	Protection point
	Delay	Protection delay, range from 0.001s to 10s.
Over Power	Over power protection	
	OPP State	OPP state: on/off
	Power	Protection point
	Delay	Protection delay, range from 0.001s to 10s.

5.5.1 Over-Current Protection (OCP)

Users can enable the OCP function and set the protection limit Level and protection delay time **Delay**. When the current (i.e., the Meter value) is greater than this protection limit and the delay time is exceeded, the power supply will enter the OCP state and output is disabled.

Possible Cause

Many reasons can cause OCP, the details are as follows:

- The set protection limit Level is lower than the current Meter value.
- The external (AC input) inputs a higher current.

- The power supply outputs a high current due to a fault.

How to Set

The operation steps to set OCP are as follows.

4. Press the [**Protect**] on the menu interface to enter the protection menu.
5. Use the knob or direct touch-click to select OCP (Off), press the on/off box and set it to On.
6. Set the current protection point and delay time and confirm by pressing [**Enter**].

5.5.2 Set Over-Power Protection (OPP)

Users can enable the over-power protection function and set an over-power protection point Level and protection delay time Delay, when the power in the circuit (i.e., Meter value) is greater than this protection point, and exceeds the delay, the power supply or load will enter the over-power protection state and output is disabled.

Possible Cause

Many reasons can cause OPP, the details are as follows:

- The set protection limit Level is lower than the power system value.
- The power supply outputs a high power due to a fault.

How to Set

The operation steps to set OPP are as follows.

4. Press the [**Protect**] on the menu interface to enter the protection menu.
5. Use the knob or direct touch-click to select OPP (Off), press the on/off box and set it to On.
6. Set the power protection point and delay time and confirm by pressing [**Enter**].

Chapter6 Generating Arbitrary Waveforms

This chapter will introduce the List, ARB, Sequence, CDARB, Sweep, Battery Simulation, Battery Charge, Battery Discharge, OCP, OPP and Dynamic functions of the IT2700 series instruments.

6.1 LIST

The IT2703 series instrument supports the function of editing LIST sequences with multiple output points. You can set up to 2000 steps per file. You can edit the voltage/current value, slope and duration of each step.

List file can be set the repeat number (0~65535), the output status at the end step. After finishing editing the List file, it is saved in the memory of the instrument, and the instrument can save up to 200 sets of List files.

6.1.1 Run List

If you have already edited the List file, you can directly recall the List file and execute the test as follows:

1. Press the **[Function]** key on the front panel to enter the advanced function selection interface, and click the List function icon to enter the list configuration interface.

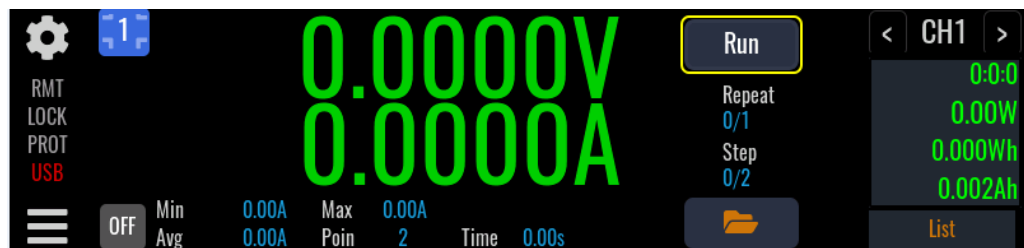

2. Press the **[Open]** key to select the file storage location, click Local or USB.
3. Select the channel and check the List file saved under that channel, and press the **[Open]** key to confirm the recall.
4. Press the front panel **[On/Off]** key to turn on that channel output.
5. Click Run in the list screen.

on screen displays the runtime and the list indicator.

6.1.2 Create a new List file

Users can create a new List file to output a list of waveforms with different amplitudes. The specific operation steps are as follows:

1. Press **Menu->Function** and enter to the function interface.
2. Click **List** icon and the instrument enters List operation mode, and the main interface displays the List operation mode.
3. Click on the File icon  in the main interface and select New to create a new List file in the prompt box.

Users can also choose to open a List file, edit a List file or delete a List file.

4. Enter the List file configuration screen as shown below.

Priority	Repeat	End	Total step: 2				
Current	1	Normal					
No.	Curr(A)	Slope(A/ms)	Time(s)	Pace	BStep	EStep	
1	1.000	0.100	1.000	Auto	On	On	
2	2.000	0.100	1.000	Auto	On	Off	

Parameter	Description
Priority	Select the voltage or current attribute of the list.
Repeat	The number of times the List file loops, 0 means infinite loops, the maximum number of loops is 65535.
End	The output state at the end of List file. It can be set to Normal, Last, Off. Normal: jumps to the output state in Fix mode, Last: keeps the last step parameter output, Off: closes the output.
Total step	Total steps. Not editable.
Add	Insert a step after the last step.
Delete	Delete the step.
	Go to the List file Save/Recall page. Open: Open an existing List file Save: Save an existing list file. Save as: Name and save the newly edited List file. Delete: Delete the list file
No.	step number of list.
Volt/Curr	Waveform amplitude for the step.
Slope	Rise slope
Time	width time for the step.
Pace	Method of step jumps to next step. Auto: when the time is out, jumps to next step Trig: receive a trigger signal, jumps to next step.
BStep	Output a trigger signal before the step
EStep	Output a trigger signal after the step

- Click  and select **[Save as]**, Name it in the prompt box and Save.
- Press Return and return to the main screen, ready to run the List file.

6.2 Generating Arbitrary Waveforms (Arb)

Each output on the power system can be modulated by the built-in arbitrary waveform generator function. This allows the output to act as a DC bias transient generator or an arbitrary waveform generator.

6.2.1 Run the Arb Waveform

1. Press the [**Function**] icon on the menu to enter the advanced function selection interface, and click the Arb function icon to enter the arbitrary waveform configuration interface.



2. In this interface, the user can directly click Run, and the machine will output according to the waveform parameters displayed at the bottom of the interface.

6.2.2 Setting the Arb Waveform Common Parameters

Under the Arb function, click the Edit button in the interface to enter the arbitrary waveform editing interface.

Select the corresponding waveform type and edit the parameters directly in the instrument interface to realize the output of different waveform shapes. This method does not need to save, but can be run directly after modification.

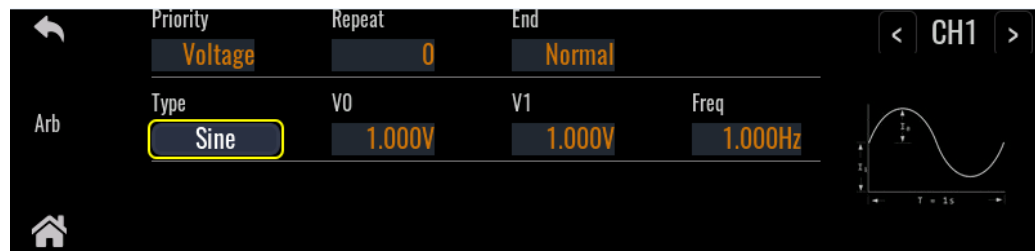

Parameter	Description
Priority	Select the voltage or current attribute of the Arb, when different output attributes are selected, the waveform definition parameters are different, for example, when Voltage is selected, V0 and V1 are set, if Current is selected, I0 and I1 are set.
Repeat	The number of times the Arb file loops, 0 means infinite loops, the maximum number of loops is 65535.
End	The output state at the end of List file. It can be set to Normal, Last, Off. Normal: jumps to the output state in Fix mode, Last: keeps the last step parameter output, Off: closes the output.
Type	Arb waveform type: Sine, Step, Pulse, Ramp, Trapezoid, Staircase, Exponential, Userdefined.

6.2.3 Configuring Sine Arb

1. Press the [**Function**] icon on the menu to enter the advanced function selection interface, and click the Arb function icon to enter the arbitrary

waveform configuration interface.

2. Select the Priority attribute.
3. Click the button corresponding to Type, select Arb type in the pop-up box to Sine.

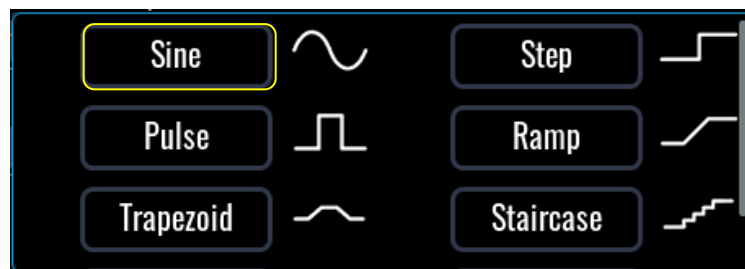

4. Configure the Sine Properties.

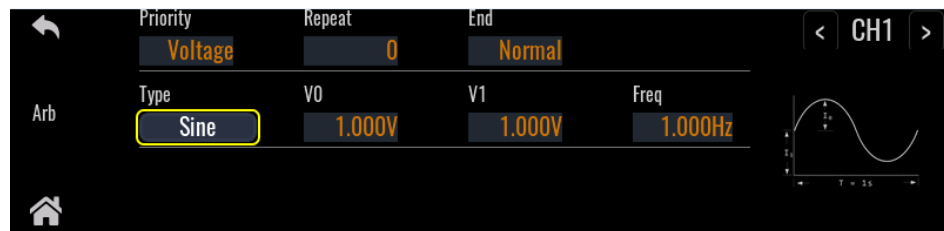

Parameter	Description
V0/ I0	The amplitude or peak value.
V1/ I1	The offset from zero. For power modules that do not generate negative values, the offset must be \geq Amplitude.
Freq	The frequency of the sine wave.

6.2.4 Configuring Step Arbs

1. Press the [Function] icon on the menu to enter the advanced function selection interface, and click the Arb function icon to enter the arbitrary waveform configuration interface.
2. Select the Priority attribute.
3. Click the button corresponding to Type, select Arb type in the pop-up box to Step.



4. Configure the Step Properties.

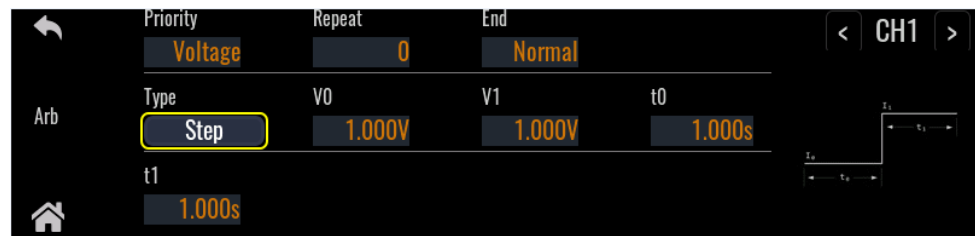

Parameter	Description
V0/ I0	The setting before the step.
V1/ I1	The setting after the step.
t0	The delay after the trigger is received but before the step occurs.
t1	The time the output remains at the end setting after the step occurs.

6.2.5 Configuring Pulse Arb

1. Press the [Function] icon on the menu to enter the advanced function selection interface, and click the Arb function icon to enter the arbitrary waveform configuration interface.
2. Select the Priority attribute.
3. Click the button corresponding to Type, select Arb type in the pop-up box to Pulse.

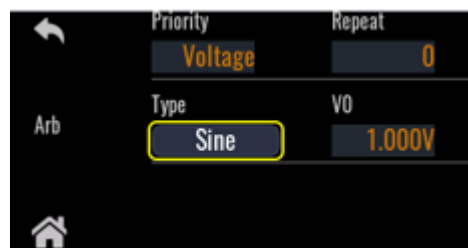

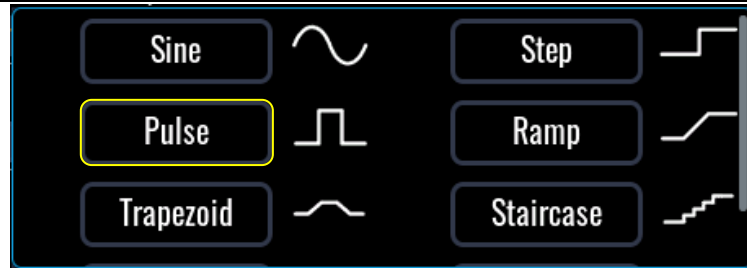

- Configure the Pulse Properties.



Parameter	Description
V0/ I0	The setting before and after the pulse.
V1/ I1	The amplitude of the pulse.
t0	The delay after the trigger is received but before the pulse starts.
t1	The width of the pulse.
t2	The time the output remains at the end setting after the pulse completes.
Freq	Enter a frequency value directly. this will change the (T0), (T1), (T2) parameters

6.2.6 Configuring Ramp Arbs

- Press the [Function] icon on the menu to enter the advanced function selection interface, and click the Arb function icon to enter the arbitrary waveform configuration interface.
- Select the Priority attribute.
- Click the button corresponding to Type, select Arb type in the pop-up box to Ramp.

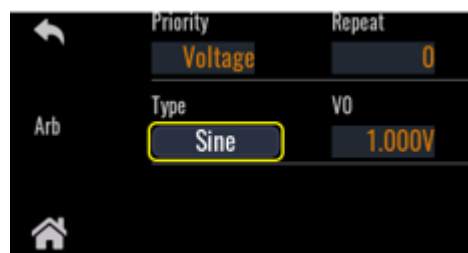

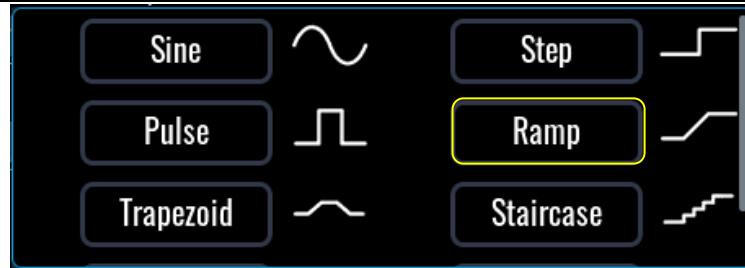

4. Configure the Ramp Properties.

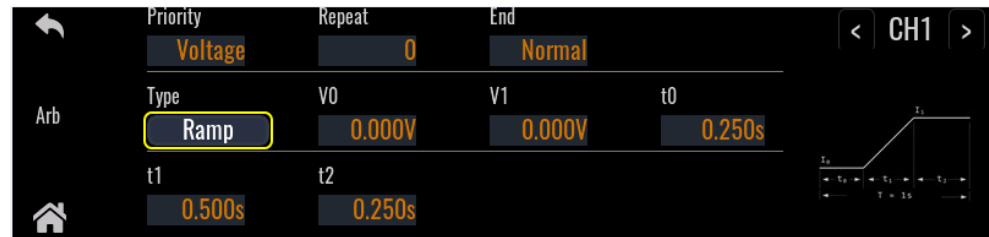

Parameter	Description
V0/ I0	The setting before the ramp.
V1/ I1	The setting after the ramp.
t0	The delay after the trigger is received but before the ramp starts.
t1	The time that the output ramps up.
t2	The time the output remains at the end setting after the ramp completes.

6.2.7 Configuring Trapezoid Arbs

1. Press the [Function] icon on the menu to enter the advanced function selection interface, and click the Arb function icon to enter the arbitrary waveform configuration interface.
2. Select the Priority attribute.
3. Click the button corresponding to Type, select Arb type in the pop-up box to Trapezoid.

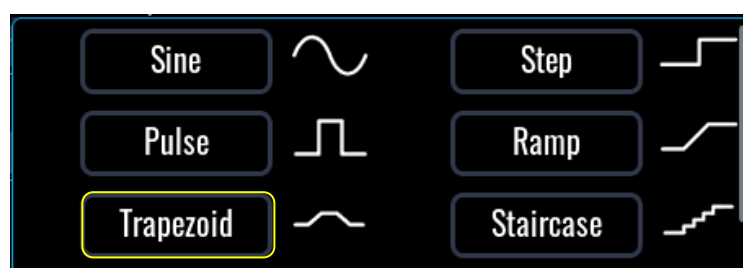
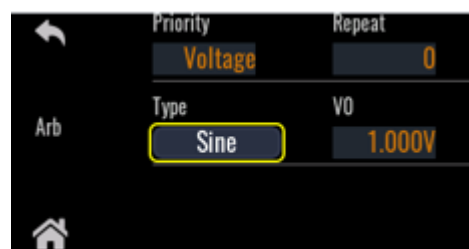

4. Configure the Trapezoid Properties.



Parameter	Description
V0/ I0	The setting before and after the trapezoid.
V1/ I1	The peak setting.
t0	The delay after the trigger is received but before the trapezoid starts.
t1	The time that the trapezoid ramps up.
t2	The width of the peak.
t3	The time that the trapezoid ramps down.
t4	The time the output remains at the end setting after the trapezoid completes.

6.2.8 Configuring Staircase Arb

1. Press the [Function] icon on the menu to enter the advanced function selection interface, and click the Arb function icon to enter the arbitrary waveform configuration interface.
2. Select the Priority attribute.
3. Click the button corresponding to Type, select Arb type in the pop-up box to Staircase.

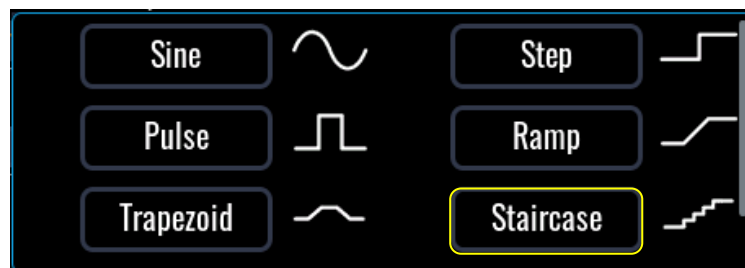

4. Configure the Staircase Properties.

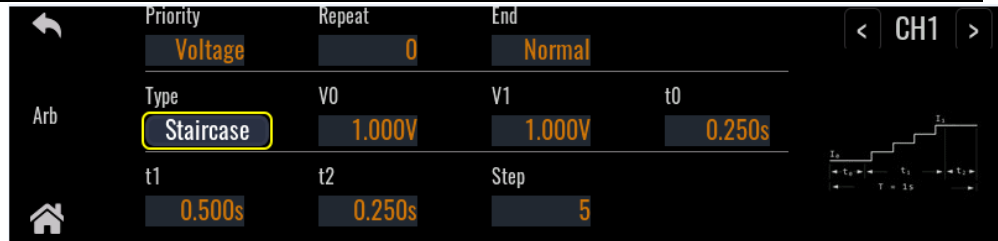

Parameter	Description
V0/ I0	The setting before the staircase.
V1/ I1	The setting after the final step. The difference between the start and end setting is divided equally between steps.
t0	The delay after the trigger is received but before the staircase starts.
t1	The time to complete all staircase steps.
t2	The time the output remains at the end setting after the staircase completes.
Step	The total number of staircase steps.

6.2.9 Configuring Exponential Arb

1. Press the [Function] icon on the menu to enter the advanced function selection interface, and click the Arb function icon to enter the arbitrary waveform configuration interface.
2. Select the Priority attribute.
3. Click the button corresponding to Type, select Arb type in the pop-up box to Exponential.

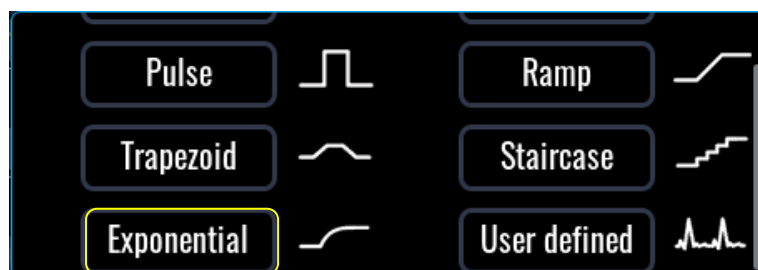
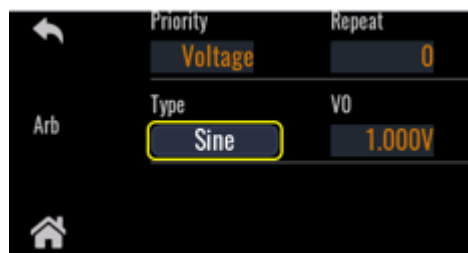

4. Configure the Exponential Properties.



Parameter	Description
V0/ I0	The setting before the waveform.
V1/ I1	The end setting of the waveform.
t0	The delay after the trigger is received but before the waveform starts.
t1	Time for the amplitude to go from the start setting to the end setting.
tc	The time constant of the curve.

6.2.10 Configuring User-Defined Arb

User-defined Arb waveforms can be used to edit waveforms via Demo software or imported via USB storage devices. Panel operation does not support editing.

1. Press the **[Function]** icon on the menu to enter the advanced function selection interface, and click the Arb function icon to enter the arbitrary waveform configuration interface.
2. Select the Priority attribute.
3. Click the button corresponding to Type, select Arb type in the pop-up box to User defined.

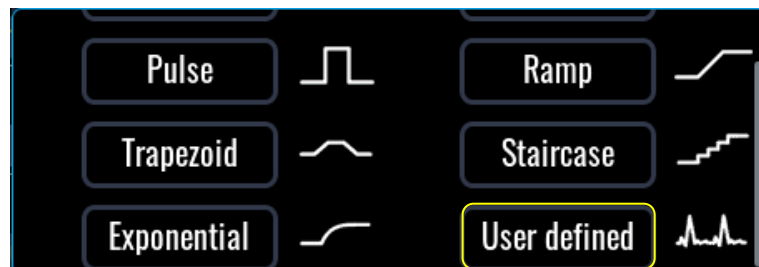
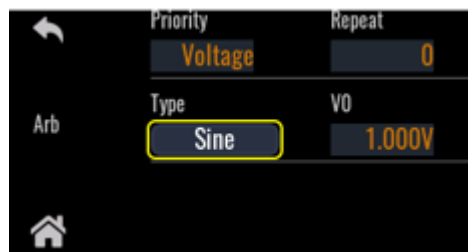

4. Import customized waveforms from USB storage devices.

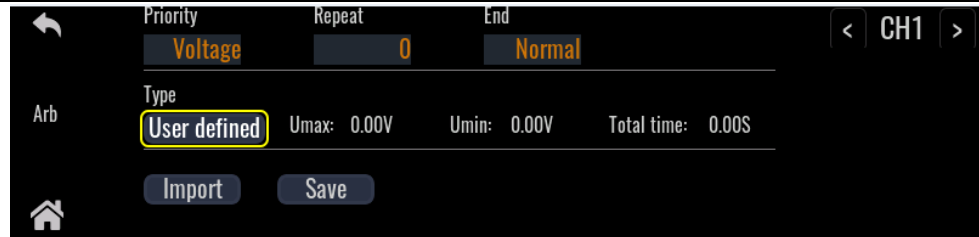

Button	Description
Import	Import waveform
Save	Save the current customized waveform in the machine or in a USB flash drive. When saved in a USB flash drive, it is saved in the form of a CSV format file, which supports secondary import.

6.3 Configuring an Arb Sequence (Arb Sequence)

The Arb Sequence allows multiple and different Arbs to run one after another in succession. Any of the standard Arb types, except for constant-dwell Arbs, can be included in the Arb sequence. All Arbs in the sequence must be of the same type; either voltage, current, resistance, or power.

As with single Arbs, each Arb in the sequence has its own repeat count, can be set for dwell or trigger pacing, and can be set to repeat continuously. Note also that a repeat count can be set for the entire sequence, and it can also be set to repeat continuously.

The following figure illustrates a sequence comprised of a step Arb, a sine Arb, and a pulse Arb. The repeat count value indicates how many times each Arb repeats before moving to the next type.

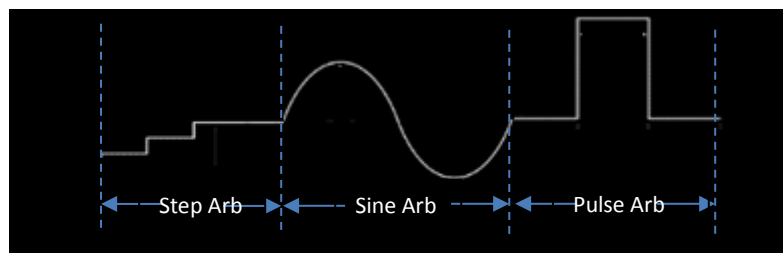

This function is realized through software or Web control. In local panel operation mode, only importing files is supported, and editing is not possible.

Import/export function

1. Press the [**Function**] icon on the menu to enter the advanced function selection interface, and click the Sequence function icon to enter the Sequence waveform configuration interface.
2. Click on the File icon  in the main interface and select New to create a new Sequence file in the prompt box.

Users can also choose to open a sequence file, edit a sequence file or delete a sequence file.

3. Enter the Arb Sequence import/export screen.

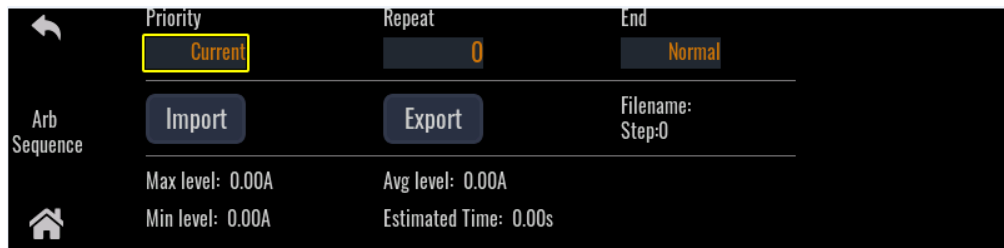

Button	Description
Import	Import csv files from local memory or USB flash drive.
Export	Export the current file to local memory or save it on a USB flash drive.
Filename	Sequence filename
Max level	Maximum level in Sequence file
Avg level	Average level in Sequence file
Min level	Min level in Sequence file
Estimated Time	Total running time

6.4 Configuring Constant-Dwell Arbs

The CDARB constant dwell waveforms are different from other Arb in that they do not have separate dwell values for each point, and the dwell time is set uniformly, and a single dwell value applies to all points. And the minimum dwell time of CD Arb is 0.001s.

Since CD Arb has many data points, users can edit waveforms by Demo software or web control, front panel operation does not support editing waveforms, only importing csv files.

1. Press the **[Function]** icon on the menu to enter the advanced function selection interface, and click the CDARB function icon to enter the Constant-Dwell Arb waveform configuration interface.
2. Click on the Edit icon in the main interface and enter to the CDARB edit interface.

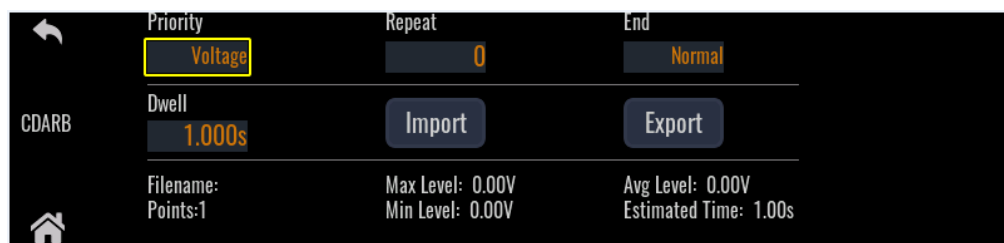

This screen sets the voltage and current attributes, the number of repetitions, the running status at the end, and the residence time maintained by a single step.

Parameter	Description
-----------	-------------

Priority	Select the voltage or current attribute of the list, when different output attributes are selected, the waveform definition parameters are different.
Repeat	The number of times the file has been looped, 0 means infinite loops, and the maximum number of loops is 65535.
End	The output state at the end of List file. It can be set to Normal, Last, Off. Normal: jumps to the output state in Fix mode, Last: keeps the last step parameter output, Off: closes the output.
Dwell Steps	per The width of time that each data point resides.

- Click the **[Import]** button and select Import Waveform Data.

6.5 Sine Sweep Waveform

The sine sweep function allows you to set the start voltage value, end voltage value, start DC, start frequency, end frequency, and other parameters to depict a sinusoidal scan waveform.

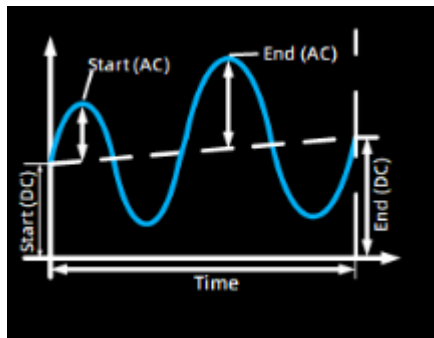

Operation Step

- Press the **[Function]** icon on the menu to enter the advanced function selection interface, and click the Sine Sweep function icon to enter the Sine sweep waveform configuration interface.
- Click Edit in the main interface to enter the sine sweep waveform editing interface.

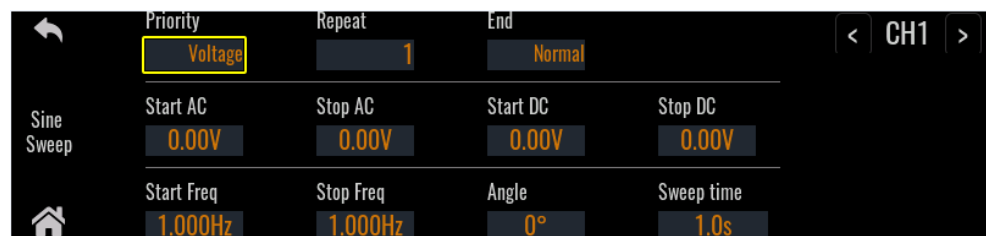

- Complete the setting of voltage and frequency related parameter values.

Parameter	Description
Priority	Select the voltage or current attribute of the list, when different output attributes are selected, the waveform definition parameters are different.

Repeat	The number of times the file has been looped, 0 means infinite loops, and the maximum number of loops is 65535.
End	The output state at the end of List file. It can be set to Normal, Last, Off. Normal: jumps to the output state in Fix mode, Last: keeps the last step parameter output, Off: closes the output.
Start AC	Start AC Amplitude
Stop AC	Stop AC Amplitude
Start DC	Start DC offset
Stop DC	Stop DC offset
Start freq	Start frequency
Stop freq	Stop frequency
Angle	The waveform start angle.
Sweep time	Total waveform duration.

- Return and press the **[On/Off]** key at the front panel to turn on the power output.
- Click the **[Run]** key to start running the sine scan waveform. The interface shows the running status.

6.6 Battery Simulation Function

This series power system can simulate battery characteristics in practical applications based on its unique bidirectional properties and the variable output impedance. You can set battery-related parameters to simulate the charge and discharge characteristics of the battery to assist with other tests.

- Press the **[Function]** icon on the menu to enter the advanced function selection interface, and click the Battery Simulation icon to enter the configuration interface.

- Click on the File icon  in the main interface and select New to create a new test file in the prompt box.

Users can also choose to open a battery file, edit a file or delete a file.

- Enter the battery simulation file configuration screen as shown below.

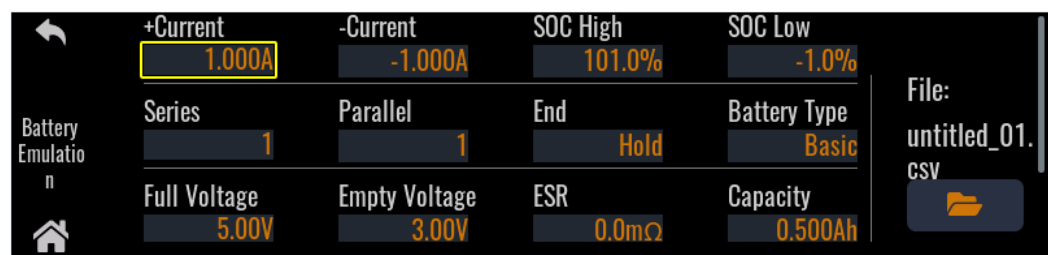

Parameter	Description
+Current	Positive current limit value

-Current	Negative current limit value
SOC High	Sets the maximum battery pack SOC limit value.
SOC Low	Sets the battery pack SOC minimum limit value.
Series	Number of batteries in series
Parallel	Number of batteries in parallel
End Type	The output state at the end of List file. It can be set to Normal, Last, Off. Normal: jumps to the output state in Fix mode, Last: keeps the last step parameter output, Off: closes the output.
Battery Type	For battery type, you can choose Basic mode or Curve mode.
Full voltage	Simulates the voltage value when the cell battery is fully charged.
Empty voltage	Simulates the voltage value when the cell battery is in the empty state.
ESR	equivalent series resistance.
Capacity	Simulates the capacity of a cell battery.
Initial Voltage	Initial battery voltage level. Check the box before setting the voltage value.
Initial Capacity	Battery initial capacity value, check the box first then set the capacity value.
Initial SOC	Sets the initial state of charge of the battery. Check the box before setting the SOC value.
Open	Open or select a battery simulation file.
New	Create a battery simulation file.
Save	Save the battery simulation file.
Save as	Save as the battery simulation file.
Delete	Delete the battery simulation file.

4. Press **[Save]** save the file.
5. Return and press the **[On/Off]** key at the front panel to turn on the power output.
6. Click the **[Run]** key to start running the waveform. The interface shows the running status.

6.7 Battery Charging Test Function

This series of power systems supports the battery charging function. Users edit the test file in the interface and call the battery test file to execute the test as needed.

Precautions

Please confirm that you have understood the general safety precautions before connection. Please pay special attention to the following safety precautions when connecting the battery.

WARNING

- When connecting the DUT (battery/capacitor), do not short-circuit the battery.
- To avoid battery short circuit, be sure to check that the test line end is not connected when connecting or disassembling the test line. When the test line end is connected with battery, short circuit may cause severe accident.
- To avoid the damage of the instrument, please make sure the positive and negative electrodes of the electrode when connecting the battery and other energy storage equipment.
- Hazardous voltages may still be present on the positive and negative electrodes after the unit is turned off; never touch the cables or electrodes immediately. Make sure that no dangerous voltage is present on the electrodes or sense terminals before they are touched.

1. Press the **[Function]** icon on the menu to enter the advanced function selection interface, and click the Battery Charge icon to enter the configuration interface.

Parameter	Description
Open	Open or select a battery charge test file.
New	Create a battery charge test file.
Edit	Edit the battery charge test file.
Delete	Save as the battery charge test file.
Run	Run the test

2. Click on the File icon  in the main interface and select New to create a new test file in the prompt box.

Enter the Battery Charge file configuration screen as shown below.

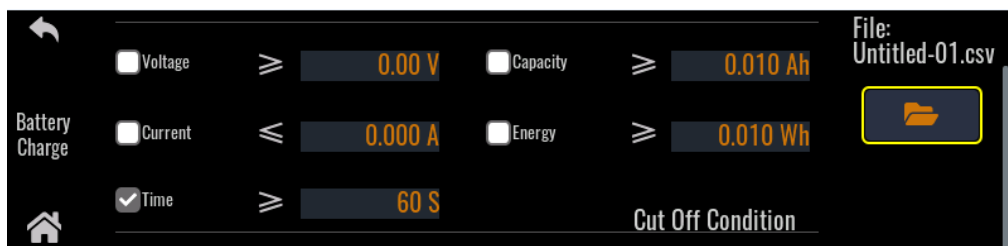

Parameter	Description
Charge Mode	Charge mode, can be select to Voltage or Current
Charge Voltage	Set the voltage value for charging
Charge Current	Set the current value for charging
Cut Off Condition	Battery charge test cut off condition
	Voltage: Charging ends when the voltage is greater than or equal to this setting.

	Current: Charging ends when the current is less than or equal to this setting.
	Time: Charging ends when the time is greater than or equal to this setting.
	Capacity: Charging ends when the capacity is greater than or equal to this setting.
	Energy: Charging ends when the energy is greater than or equal to this setting.
Open	Open or select a battery charge test file.
New	Create a battery charge test file.
Save	Save the battery charge test file.
Save as	Save as the battery charge test file.
Delete	Delete the battery charge test file.

3. Press **[Save]** save the file.
4. Return and press the **[On/Off]** key at the front panel to turn on the power output.
5. Click the **[Run]** key to start running the waveform. The interface shows the running status.

6.8 Battery Discharging Test Function

This series of power system supports battery discharge function in bidirectional source mode or load mode. Users edit the test file in the interface and call the battery test file to execute the test as needed.

Precautions

Please confirm that you have understood the general safety precautions before connection. Please pay special attention to the following safety precautions when connecting the battery.

WARNING

- When connecting the DUT (battery/capacitor), do not short-circuit the battery.
- To avoid battery short circuit, be sure to check that the test line end is not connected when connecting or disassembling the test line. When the test line end is connected with battery, short circuit may cause severe accident.
- To avoid the damage of the instrument, please make sure the positive and negative electrodes of the electrode when connecting the battery and other energy storage equipment.
- Hazardous voltages may still be present on the positive and negative electrodes after the unit is turned off; never touch the cables or electrodes immediately. Make sure that no dangerous voltage is present on the electrodes or sense terminals before they are touched.

1. Press the [**Function**] icon on the menu to enter the advanced function selection interface, and click the Battery Discharge icon to enter the configuration interface.

Parameter	Description
Open	Open or select a battery charge test file.
New	Create a battery charge test file.
Edit	Edit the battery charge test file.
Delete	Save as the battery charge test file.
Run	Run the test

2. Click on the File icon  in the main interface and select New to create a new test file in the prompt box.

Enter the Battery Charge file configuration screen as shown below.

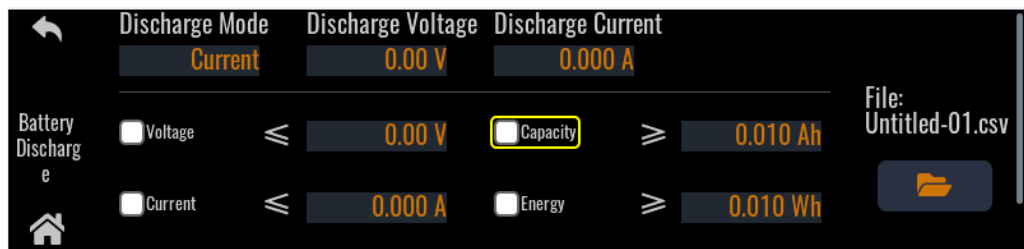

Parameter	Description
Discharge Mode	Discharge mode, can be select to Voltage or Current
Discharge Voltage	Set the voltage value for Discharging
Discharge Current	Set the current value for Discharging
Cut Off Condition	Battery charge test cut off condition
	Voltage: Discharging ends when the voltage is less than or equal to this setting.
	Current: Discharging ends when the current is less than or equal to this setting.
	Time: Charging ends when the time is greater than or equal to this setting.
	Capacity: Charging ends when the capacity is greater than or equal to this setting.
	Energy: Charging ends when the energy is greater than or equal to this setting.
Open	Open or select a battery charge test file.
New	Create a battery charge test file.
Save	Save the battery charge test file.

Save as	Save as the battery charge test file.
Delete	Delete the battery charge test file.

3. Press [**Save**] save the file.
4. Return and press the [**On/Off**] key at the front panel to turn on the power output.
5. Click the [**Run**] key to start running the waveform. The interface shows the running status.

Chapter7 System-Related Functions

7.1 Setting System General Parameters

Click **Menu** -> **General** and enter to the general menu interface.

Set the Power-on State

This parameter determines the state of the AC source after power up.

The procedures to set the menu item are as follows.

1. Press the **General** under the system menu.
2. Turn the knob to select the **Power on settings**.
 - **Reset**: Default value, indicates when the instrument is powered on, the instrument will initialize some parameter settings or state, such as output voltage and output current.
 - **Last**: Indicates when powered on, the instrument will remain the same parameter settings and output status as last time you powered off the instrument.
 - **Last+Off**: Indicates when powered on, the instrument will remain the same settings as last time you powered off the instrument, but the output status is **Off**.

Set Slope Type for Source mode

This option is used to set the type of power supply slope setting. Selecting **Rate** indicates that the set slope is a speed value. Selecting **Time** indicates that the set slope is a time value.

Setting Current Display Symbol for Load

This option is used to set the symbol of the load current display. Selecting **Positive+**, the load current displays positive current value. Selecting **Negative-**, the load current displays a negative current value.

Restored to Factory Setting

This menu item is used to restore some parameter settings to factory setting values.

The procedures to set the menu item are as follows.

1. Select the **General** under system menu.
2. Press **Reset** in **Factory default settings**.

System Reboot

This option is used to reboot the system.

7.2 Setting Instrument General Function

Enter **Menu** -> **Preference** to set the general parameters related to the instrument display.

Set the keyboard sound

This item can set the key sound state.

- If **Key Click Buzzer** is set to ON mode, then when you press a button, the instrument will beep. If it is OFF mode, the beeper will not make a sound. The default set is in ON mode.
- If **Alarm Buzzer** is set to ON mode, the buzzer sounds when protection occurs; if it is OFF, the buzzer does not sound.

Set the screen brightness

This item can set the screen brightness. Set the screen brightness within the range 1 to 10 by pressing number keys on the front panel. The larger the number is, the higher the screen brightness is. You can also set the screen brightness by rotating the knob on the front panel.

Set the Soft Keyboard

The user can open the soft panel in the menu. When the parameter is set to ON, the soft keyboard is enabled. And when setting parameters on the screen, the soft keyboard appears. Convenient users directly touch screen to select the number.

Set the Knob Function

Set the **Knob immediately Effective** function. If set to ON, the Knob setting will take effect immediately. If set to OFF, press Enter to confirm the effect after the Knob setting is completed.

Default Screen Display Settings

This menu item allows you to set the default display of the screen, for example, select Meter3 and the meter interface displays 3 channel screens after power on. The user can select Meter1, Meter3, Meter6 in the menu.

Select Language

Users can select the instrument language type from the menu.

7.3 Screen Lock Function

In the main interface of the instrument, click  and then click the LOCK button on the left side of the pop-up control panel to lock the instrument screen. In the screen lock state, click any position of the screen, the interface will prompt "Do you really want to unlock it?". Users can choose ok to release the screen lock status.

7.4 Switching Local/Remote Mode

When the instrument is in RMT remote control mode, the user can switch the instrument from remote mode to local mode by clicking on the screen and selecting OK when prompted in the pop-up control panel.

After the instrument is powered up, the default is the local operation mode. In local operation mode, the touch screen can be operated normally, and the screen is not available when the power is in remote operation mode.

Switching from local to remote operation mode can be controlled by PC. The

change of operation mode does not affect the set parameters of the instrument.

7.5 Timing Output Function

The IT2703 series power system can be installed with up to 6 modules, and different channels can be set with On delay or Off delay, through which timing outputs between multiple channels can be realized.

Users click to select the Delays icon in Menu interface and enter to the channel delay time setting interface. As shown in below.

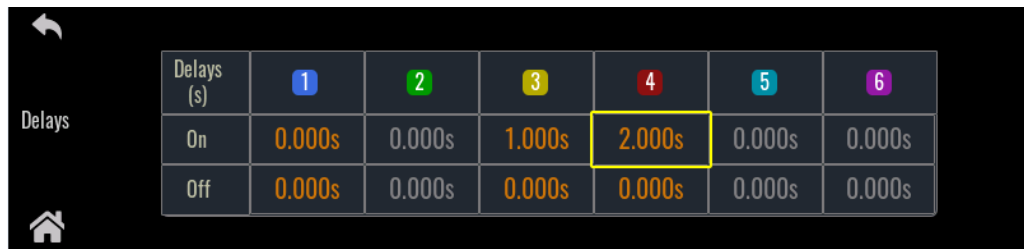

Delays (s)	1	2	3	4	5	6
On	0.000s	0.000s	1.000s	2.000s	0.000s	0.000s
Off	0.000s	0.000s	0.000s	0.000s	0.000s	0.000s

Under this interface, users setting the output on delay time and off delay time for each channel.

This function can be used to control the output delay of independent channels. It can be used in combination with the ALL ON or ALL OFF key to realize the timing output between channels. It can be used to test the timing power supply or power off requirement between different channels.

7.6 Channel Synchronized Output Function

Output synchronization can be selected between multiple channels of the IT2703 series. The user checks the box in front of the channel, 1-6 channels can be selected to be fully synchronized or partially synchronized.

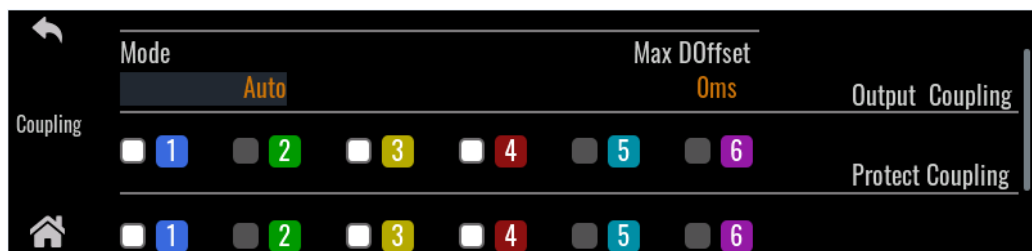

When synchronization mode is selected to Auto, the instrument adjusts the delay time between the channels by itself to realize synchronization On or synchronization Off. When synchronization mode is selected to Manual, the user needs to set the synchronization delay time. This delay time is superimposed with the On Delay and Off delay of each channel, and the final output schematic is shown below.

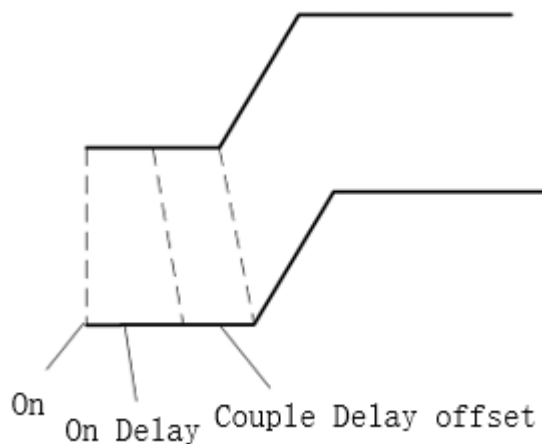

7.7 Remote Measurement Function

The IT2700 series power system supports two connection methods: Local measurement and Remote sensing. The remote sensing is used for maximizing measurement accuracy. (Refer to 2.6 Connecting Test Lines).

The procedures to set the menu item are as follows.

1. Press the **Menu->Measure** in menu interface.
2. Select **Remote Sense** and turn on the function state.
 - Off: Default value, indicates turn the sense function off.
 - On: Indicates turn the sense function on.

7.8 Save and Recall Operations

The power system can save common parameters in nonvolatile memory for user to recall conveniently.

The saved parameters include:

- Power supply mode
- Present output mode
- Config menu settings

You can do the save and recall operations by the following two methods.

- In the menu interface, press the **Save** button to save the parameters. Press the **Recall** to recall the parameters.
- SCPI commands: *SAV and *RCL

Saving the parameters

The save parameter operates as follows:

1. Enter to **Menu->Save** interface.
2. Select the save data location.
3. Press [**Enter**].

When saving is completed, the interface will display the saved detailed parameters.

Recalling the Parameters

Recalling the data in the memory and used as the present setting value.

1. Enter to **Menu->Recall** interface.
2. Select the recalling data location.
3. Press [**Enter**].

When recalling is completed, the interface will display the saved detailed parameters.

7.9 Screen Capture Function

IT2700 series power supply has the screen capture function. Insert the USB equipment into the USB interface of the front panel, and press **right and left arrow keys** at the same time on the front panel to capture and save the current screen into the USB disk.

When you need the screen capture function, the USB type under the system menu needs to be set to **Host**.

7.10 Query the System Log

The IT2700 series power system provides the system operation Log query function. On the Menu interface of the front panel, click Log to enter the Log query interface. You can view historical system operation records on this screen.

7.11 Query the System Information

Users can click **Menu->Info** to enter the system information interface to view all channel information, including channel module name, SN number, specifications, and firmware program version.

When the instrument requires maintenance, the user needs to check this information for confirmation.

7.12 System Management Functions

IT2700 series power system supports system management function, click Admin function in Menu to enter the system management interface and log in, in this interface you can clean up the data and change the system password.

The default password is 2700 when the instrument is shipped from the factory.

Sanitize

Erase system logs and information, including all functional data and files.

Change Password

Change the system administration password.

7.13 Digital I/O Function

This series power system supports digital I/O function. The user can realize logic control over high and low level input or output by related configurations in the system menu.

Pins Introduction

Different I/O implements different functions. The detailed functions description are shown in the figure below:

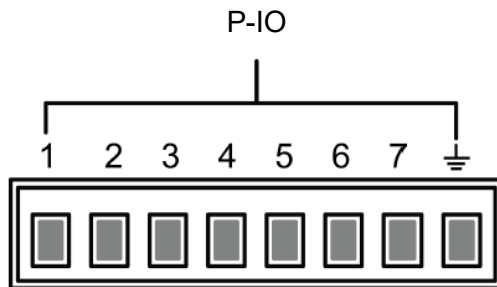

Pin	Type	Description	Properties
Digital IO-1	Input/Output	Remote Inhibit, Turn off the output under emergency status	Level signal
Digital IO-2	Input/Output	PS, Protection state indicator	Pulse signal
Digital IO-3	Input/Output	PS Clear, Clear the protection state	Level signal
Digital IO-4	Input/Output	OnOff Status, OnOff-status indicator	Level signal
Digital IO-5	Input/Output	Sync, synchronous control	Pulse signal
Digital IO-6	Input/Output	On Couple, Turn on the output	Pulse signal
Digital IO-7	Input/Output	Off Couple, Turn off the output	Pulse signal
⏏		Ground terminal, that is, the negative terminal corresponding to each of the above 7 pins.	

General Digital I/O Function

- Signal definition

Digital I/O functions involve input and output levels and pulse signals. The input signal is the control signal provided externally to IT2703, the output signal is the level signal provided externally by IT2703, and the pulse signal is the edge signal switched between high and low levels.

Input signal	High level signal	Typical: 5V Range: 1.6V-15V Current: $\leq 100\text{mA}$
--------------	-------------------	--

	Low level signal	Typical: 0V Range: -5V-0.8V Current: $\leq 100\text{mA}$
Output signal	High level signal	Voltage level: 5V Current: $\leq 1\text{mA}$
	Low level signal	Voltage level: 0V Current: 0.5mA
Pulse	Level rise slope	10us
	Level fall slope	2us
	Width	Can be set from 5us to 500us

- Input/Output Function

The IO-1 ~ IO-7 pins are featured default function, the user can setting the function of pin according to requirement. The Input and Output are the general digital I/O function, and the parameter settings and functions of the seven pins are the same.

The IO-1~IO-7 pins provide default functions. Users can realize control according to the functions defined. Users can also reset the input or output properties of the present pin and customize the function use of the pin according to their needs.

When pins 1 to 7 are configured to Output function, when send the command (IO:STATE 1/0) to instrument, the IO pin can output high level (False) or low level (True).

When pins 1 to 7 are configured to Input function, an external signal can be Input to this pin, and the instrument can detect the state of the external signal.

- Signal Revert

Select Invert or not under the IO Settings menu. If setting to OFF, it means the default level will be valid. If setting to ON, it means the valid signal is reversed. For example, the IO-1 pin is inhibit output by default and the high level is valid, when select revert ON, the low level is valid and the instrument output is disabled.

Digital IO-1

IO-1 pin can be set to **【Inhibit】**, **【Digital-In】**, **【Digital-Out】**, **【Trig-In】**, **【Trig-Out】**

The default function is inhibit output. When the IO pin is configured for a Inhibit function and the level signal is low, the output of the machine is forbidden. At this point, Pin 1 has a bi-directional I/O function, which can both receive the level signal input from the external instrument and output the level signal outward.default level is high, and low is valid when entering. Outgoing output also generates low level signals.

Digital IO-2

IO-2 pin can be set to **【PS】**, **【Digital-In】**, **【Digital-Out】**, **【Trig-In】**, **【Trig-Out】**

The default function is protection state indicator. IO-2 pin will output high or low

level based on whether the instrument is under protection or not. Under normal conditions (Not under protection), and when pin2 is under default setting (Not Invert), pin2 outputs high level; when the instrument is under protection, pin2 outputs low level. When pin2 is set to Invert, the output level is completely opposite.

Digital IO-3

IO-3 pin can be set to **【PS-clear】**, **【Digital-In】**, **【Digital-Out】**, **【Trig-In】**, **【Trig-Out】**

The default function is to clear the protected state. When the protection occurs, the protection state can be cleared through this pin, so that the instrument can continue to output normally.

IO-3 is bi-directional, that is, when the power supply is in a protected state, the instrument can receive a pulse signal from an external input through IO-3 for clean protection operation, or when the power supply is in a protected state, the clean protection can generate a pulse signal from IO-3.

Digital IO-4

IO-4 can be set to **【OnOff-status】**, **【Digital-In】**, **【Digital-Out】**, **【Trig-In】**, **【Trig-Out】**

The default function is to indicate the output state of the power supply, in case of output is ON, output 5V, otherwise, output 0V.

When pin4 is set to Invert, the output level is completely opposite.

Digital IO-5

IO-4 pin can be set to **【Sync-in】**, **【Sync-out】**, **【Digital-In】**, **【Digital-Out】**, **【Trig-In】**, **【Trig-Out】**

This function can be used to simulate the six-phase output mode, in which one IT2700 outputs a synchronous signal to another IT2700, and the second power supply runs synchronously with the frequency and phase of the first power supply to realize the six-phase output function.

【Sync-in】 : Synchronous input function, which is used to output frequency lock or phase lock with the external signal. At this time, the machine synchronizes the frequency or phase information input from the IO-5 pin.

【Sync-out】 : Synchronous output function, the IT2700 produces synchronous signal to the outside, which is AC zero crossing pulse signal sent from the IO port.

Digital IO-6

IO-6 pin can be set to **【On-Couple】**, **【Digital-In】**, **【Digital-Out】**, **【Trig-In】**, **【Trig-Out】**

Digital IO-7

IO-7 pin can be set to **【Off-Couple】**, **【Digital-In】**, **【Digital-Out】**, **【Trig-In】**, **【Trig-Out】**

Chapter8 Technical Specifications

This chapter will introduce the main technical parameters of IT2700, such as rated voltage/current/power and so on. Besides, this part will introduce the working environment and storage temperature.



NOTE

All the above parameters are subject to change without prior notice from ITECH.

8.1 Supplemental characteristics

Recommended calibration frequency: once a year

Cooling style: fans

8.2 Main technical parameters

IT2703 Main frame specifications

AC Input	Voltage	sing phase: 100V~240V
	Frequency	50/60Hz
Max. apparent power	1.8kVA	
Max. input current ⁽¹⁾	10Aac	
Max. efficiency	95%	
Power Factor	0.99	
DC component	≤0.2A	
Current harmonics	≤3%	
Standard Interface	USB/LAN/CAN/Digit-IO	
Command Response Time	0.1ms	
Max. Channel	6	
Display Size	4.28"	
Display resolution	800*200	
Working Temperature	0~40℃	
Storage Temperature	-10℃~70℃	
IP	IP20	
Isolation DC to GND	3500Vdc	
Cooling	Air	
Dimension(mm)	437mm*43.5mm*580mm (main frame size) 437mm*56.9mm*600.7mm (include handle size)	
Weight(Main Frame)	10kg	

Note:

(1) AC current will be limited to 10Aac and power limiting may occur at low input voltage. Example: AC input voltage is single phase 100Vac, power limit is:
 $P=100Vac*10Aac=1000VA$

IT27134R

Model	IT27134R DC power supply	
Rated value	Voltage	0~30V
	Current	0~15A
	Power	0~200W
	Series internal resistance (CV Priority)	0~1Ω
Setup Resolution	Voltage	0.001V
	Current	0.001A
	Power	0.01W
	Series internal resistance (CV Priority)	0.0001Ω
Read Back Resolution	Voltage	0.0001V
	Current	0.0001A
	Power	0.01W
Setup Accuracy	Voltage	≤0.02% + 0.02%FS
	Current	≤0.05% + 0.05%FS
	Power	≤0.1% + 0.2%FS
	Series internal resistance (CV Priority)	≤1%FS
Read Back Accuracy	Voltage	≤0.02% + 0.02%FS
	Current	≤0.05% + 0.05%FS
	Power	≤0.1% + 0.2%FS
Voltage ripple ⁽¹⁾	Vpeak	≤30mVpp
	Vrms	≤5mV
Setup Temperature Coefficient	Voltage	≤20ppm/°C
	Current	≤30ppm/°C
Read Back Temperature	Voltage	≤20ppm/°C

Coefficient	Current	$\leq 30\text{ppm}/^{\circ}\text{C}$
Rise Time(no load)	Voltage	$\leq 10\text{ms}$
Rise Time(full load)	Voltage	$\leq 20\text{ms}$
Fall Time(no load)	Voltage	$\leq 0.5\text{s}$
Fall Time(full load)	Voltage	$\leq 50\text{ms}$
Transient Response Time ⁽²⁾	Voltage	$\leq 1\text{ms}$
Line Regulation	Voltage	$\leq 0.005\% + 0.005\%\text{FS}$
	Current	$\leq 0.015\% + 0.015\%\text{FS}$
Load Regulation	Voltage ⁽³⁾	$\leq 0.005\% + 0.005\%\text{FS}$
	Current	$\leq 0.015\% + 0.015\%\text{FS}$
Output protection	OCP	15.3A
	OVP	30.6V
	OPP	204W
Remote Sense Compensation Voltage		$\leq 3\text{V}$
Isolation DC to GND		800Vdc
Working Temperature		0~40°C
Storage Temperature		-10°C~70°C
IP		IP20
Cooling		Air
Dimension (mm)		320mm*50mm*40mm
Weight(net)		0.6kg

Note:

- (1) Ripple peak and RMS doubled for voltages 0.5V and below
- (2) 10% rated current to 90% rated current
- (3) Under sense mode
- (4) Voltage rise time from 10% to 90% of rated voltage and voltage fall time from 90% to 10% of rated voltage

IT27135R

Model	IT27135R DC power supply
-------	--------------------------

Rated value	Voltage	0~60V
	Current	0~10A
	Power	0~200W
	Series internal resistance (CV Priority)	0~1Ω
Setup Resolution	Voltage	0.001V
	Current	0.001A
	Power	0.01W
	Series internal resistance (CV Priority)	0.0001Ω
Read Back Resolution	Voltage	0.0001V
	Current	0.0001A
	Power	0.01W
Setup Accuracy	Voltage	≤0.02% + 0.02%FS
	Current	≤0.05% + 0.05%FS
	Power	≤0.1% + 0.2%FS
	Series internal resistance (CV Priority)	≤1%FS
Read Back Accuracy	Voltage	≤0.02% + 0.02%FS
	Current	≤0.05% + 0.05%FS
	Power	≤0.1% + 0.2%FS
Voltage ripple ⁽¹⁾	V _{peak}	≤60mV _{pp}
	V _{rms}	≤10mV
Setup Temperature Coefficient	Voltage	≤20ppm/°C
	Current	≤30ppm/°C
Read Back Temperature Coefficient	Voltage	≤20ppm/°C
	Current	≤30ppm/°C
Rise Time(no load)	Voltage	≤10ms
Rise Time(full load)	Voltage	≤20ms
Fall Time(no load)	Voltage	≤0.5s
Fall Time(full load)	Voltage	≤50ms

Transient Response Time ⁽²⁾	Voltage	≤1ms
Line Regulation	Voltage	≤0.005% + 0.005%FS
	Current	≤0.015% + 0.015%FS
Load Regulation	Voltage ⁽³⁾	≤0.005% + 0.005%FS
	Current	≤0.015% + 0.015%FS
Output protection	OCP	10.2A
	OVP	61.2V
	OPP	204W
Remote Sense Compensation Voltage	≤6V	
Isolation DC to GND	800Vdc	
Working Temperature	0~40°C	
Storage Temperature	-10°C~70°C	
IP	IP20	
Cooling	Air	
Dimension (mm)	320mm*50mm*40mm	
Weight(net)	0.6kg	

Note:

- (1) Ripple peak and RMS doubled for voltages 0.5V and below
- (2) 10% rated current to 90% rated current
- (3) Under sense mode
- (4) Voltage rise time from 10% to 90% of rated voltage and voltage fall time from 90% to 10% of rated voltage

IT27137R

Model	IT27137R DC power supply	
Rated value	Voltage	0~150V
	Current	0~5A
	Power	0~200W
	Series internal resistance (CV Priority)	0~1Ω
Setup Resolution	Voltage	0.01V

	Current	0.001A
	Power	0.01W
	Series internal resistance (CV Priority)	0.0001Ω
Read Back Resolution	Voltage	0.0001V
	Current	0.0001A
	Power	0.01W
Setup Accuracy	Voltage	$\leq 0.02\% + 0.02\%FS$
	Current	$\leq 0.05\% + 0.05\%FS$
	Power	$\leq 0.1\% + 0.2\%FS$
	Series internal resistance (CV Priority)	$\leq 1\%FS$
Read Back Accuracy	Voltage	$\leq 0.02\% + 0.02\%FS$
	Current	$\leq 0.05\% + 0.05\%FS$
	Power	$\leq 0.1\% + 0.2\%FS$
Voltage ripple ⁽¹⁾	V _{peak}	$\leq 150mV_{pp}$
	V _{rms}	$\leq 30mV$
Setup Temperature Coefficient	Voltage	$\leq 20ppm/^{\circ}C$
	Current	$\leq 30ppm/^{\circ}C$
Read Back Temperature Coefficient	Voltage	$\leq 20ppm/^{\circ}C$
	Current	$\leq 30ppm/^{\circ}C$
Rise Time(no load)	Voltage	$\leq 10ms$
Rise Time(full load)	Voltage	$\leq 20ms$
Fall Time(no load)	Voltage	$\leq 0.5s$
Fall Time(full load)	Voltage	$\leq 50ms$
Transient Response Time ⁽²⁾	Voltage	$\leq 1ms$
Line Regulation	Voltage	$\leq 0.005\% + 0.005\%FS$
	Current	$\leq 0.015\% + 0.015\%FS$
Load Regulation	Voltage ⁽³⁾	$\leq 0.005\% + 0.005\%FS$

	Current	$\leq 0.015\% + 0.015\%FS$
Output protection	OCP	5.1A
	OVP	153V
	OPP	204W
Remote Sense Compensation Voltage	$\leq 15V$	
Isolation DC to GND	800Vdc	
Working Temperature	0~40°C	
Storage Temperature	-10°C~70°C	
IP	IP20	
Cooling	Air	
Dimension (mm)	320mm*50mm*40mm	
Weight(net)	0.6kg	

Note:

- (1) Ripple peak and RMS doubled for voltages 0.5V and below
- (2) 10% rated current to 90% rated current
- (3) Under sense mode
- (4) Voltage rise time from 10% to 90% of rated voltage and voltage fall time from 90% to 10% of rated voltage

IT27154R

Model	IT27154R DC power supply	
Rated value	Voltage	0~30V
	Current	0~30A
	Power	0~500W
	Series internal resistance (CV Priority)	0~1Ω
Setup Resolution	Voltage	0.001V
	Current	0.001A
	Power	0.01W
	Series internal resistance (CV Priority)	0.0001Ω
Read Back Resolution	Voltage	0.0001V
	Current	0.0001A
	Power	0.01W

Setup Accuracy	Voltage	$\leq 0.02\% + 0.02\%FS$
	Current	$\leq 0.05\% + 0.05\%FS$
	Power	$\leq 0.1\% + 0.2\%FS$
	Series internal resistance (CV Priority)	$\leq 1\%FS$
Read Back Accuracy	Voltage	$\leq 0.02\% + 0.02\%FS$
	Current	$\leq 0.05\% + 0.05\%FS$
	Power	$\leq 0.1\% + 0.2\%FS$
Voltage ripple ⁽¹⁾	V _{peak}	$\leq 30mV_{pp}$
	V _{rms}	$\leq 5mV$
Setup Temperature Coefficient	Voltage	$\leq 20ppm/^{\circ}C$
	Current	$\leq 30ppm/^{\circ}C$
Read Back Temperature Coefficient	Voltage	$\leq 20ppm/^{\circ}C$
	Current	$\leq 30ppm/^{\circ}C$
Rise Time(no load)	Voltage	$\leq 10ms$
Rise Time(full load)	Voltage	$\leq 20ms$
Fall Time(no load)	Voltage	$\leq 0.5s$
Fall Time(full load)	Voltage	$\leq 50ms$
Transient Response Time ⁽²⁾	Voltage	$\leq 1ms$
Line Regulation	Voltage	$\leq 0.005\% + 0.005\%FS$
	Current	$\leq 0.015\% + 0.015\%FS$
Load Regulation	Voltage ⁽³⁾	$\leq 0.005\% + 0.005\%FS$
	Current	$\leq 0.015\% + 0.015\%FS$
Output protection	OCP	30.6A
	OVP	30.6V
	OPP	510W
Remote Sense Compensation Voltage	$\leq 3V$	
Isolation DC to GND	800Vdc	

Working Temperature	0~40℃
Storage Temperature	-10℃~70℃
IP	IP20
Cooling	风冷
Dimension (mm)	320mm*100mm*40mm
Weight(net)	1.0kg

Note:

- (1) Ripple peak and RMS doubled for voltages 0.5V and below
- (2) 10% rated current to 90% rated current
- (3) Under sense mode
- (4) Voltage rise time from 10% to 90% of rated voltage and voltage fall time from 90% to 10% of rated voltage

IT27155R

Model	IT27155R DC power supply	
Rated value	Voltage	0~60V
	Current	0~20A
	Power	0~500W
	Series internal resistance (CV Priority)	0~1Ω
Setup Resolution	Voltage	0.001V
	Current	0.001A
	Power	0.01W
	Series internal resistance (CV Priority)	0.0001Ω
Read Back Resolution	Voltage	0.0001V
	Current	0.0001A
	Power	0.01W
Setup Accuracy	Voltage	≤0.02% + 0.02%FS
	Current	≤0.05% + 0.05%FS
	Power	≤0.1% + 0.2%FS
	Series internal resistance (CV Priority)	≤1%FS
Read Back Accuracy	Voltage	≤0.02% + 0.02%FS
	Current	≤0.05% + 0.05%FS

	Power	$\leq 0.1\% + 0.2\%FS$
Voltage ripple ⁽¹⁾	Vpeak	$\leq 60mV_{pp}$
	Vrms	$\leq 10mV$
Setup Temperature Coefficient	Voltage	$\leq 20ppm/^{\circ}C$
	Current	$\leq 30ppm/^{\circ}C$
Read Back Temperature Coefficient	Voltage	$\leq 20ppm/^{\circ}C$
	Current	$\leq 30ppm/^{\circ}C$
Rise Time(no load)	Voltage	$\leq 10ms$
Rise Time(full load)	Voltage	$\leq 20ms$
Fall Time(no load)	Voltage	$\leq 0.5s$
Fall Time(full load)	Voltage	$\leq 50ms$
Transient Response Time ⁽²⁾	Voltage	$\leq 1ms$
Line Regulation	Voltage	$\leq 0.005\% + 0.005\%FS$
	Current	$\leq 0.015\% + 0.015\%FS$
Load Regulation	Voltage ⁽³⁾	$\leq 0.005\% + 0.005\%FS$
	Current	$\leq 0.015\% + 0.015\%FS$
Output protection	OCP	20.4A
	OVP	61.2V
	OPP	510W
Remote Sense Compensation Voltage		$\leq 6V$
Isolation DC to GND		800Vdc
Working Temperature		0~40 $^{\circ}C$
Storage Temperature		-10 $^{\circ}C$ ~70 $^{\circ}C$
IP		IP20
Cooling		Air
Dimension (mm)		320mm*100mm*40mm
Weight(net)		1.0kg

Note:

- (1) Ripple peak and RMS doubled for voltages 0.5V and below
- (2) 10% rated current to 90% rated current
- (3) Under sense mode
- (4) Voltage rise time from 10% to 90% of rated voltage and voltage fall time from 90% to 10% of rated voltage

IT27157R

Model	IT27157R DC power supply	
Rated value	Voltage	0~150V
	Current	0~10A
	Power	0~500W
	Series internal resistance (CV Priority)	0~1Ω
Setup Resolution	Voltage	0.01V
	Current	0.001A
	Power	0.01W
	Series internal resistance (CV Priority)	0.0001Ω
Read Back Resolution	Voltage	0.0001V
	Current	0.0001A
	Power	0.01W
Setup Accuracy	Voltage	≤0.02% + 0.02%FS
	Current	≤0.05% + 0.05%FS
	Power	≤0.1% + 0.2%FS
	Series internal resistance (CV Priority)	≤1%FS
Read Back Accuracy	Voltage	≤0.02% + 0.02%FS
	Current	≤0.05% + 0.05%FS
	Power	≤0.1% + 0.2%FS
Voltage ripple ⁽¹⁾	V _{peak}	≤150mV _{pp}
	V _{rms}	≤30mV
Setup Temperature Coefficient	Voltage	≤20ppm/°C
	Current	≤30ppm/°C
Read Back Temperature	Voltage	≤20ppm/°C

Coefficient	Current	$\leq 30\text{ppm}/^{\circ}\text{C}$
Rise Time(no load)	Voltage	$\leq 10\text{ms}$
Rise Time(full load)	Voltage	$\leq 20\text{ms}$
Fall Time(no load)	Voltage	$\leq 0.5\text{s}$
Fall Time(full load)	Voltage	$\leq 50\text{ms}$
Transient Response Time ⁽²⁾	Voltage	$\leq 1\text{ms}$
Line Regulation	Voltage	$\leq 0.005\% + 0.005\%\text{FS}$
	Current	$\leq 0.015\% + 0.015\%\text{FS}$
Load Regulation	Voltage ⁽³⁾	$\leq 0.005\% + 0.005\%\text{FS}$
	Current	$\leq 0.015\% + 0.015\%\text{FS}$
Output protection	OCP	10.2A
	OVP	153V
	OPP	510W
Remote Sense Compensation Voltage	$\leq 15\text{V}$	
Isolation DC to GND	800Vdc	
Working Temperature	0~40°C	
Storage Temperature	-10°C~70°C	
IP	IP20	
Cooling	Air	
Dimension (mm)	320mm*100mm*40mm	
Weight(net)	1.0kg	

Note:

- (1) Ripple peak and RMS doubled for voltages 0.5V and below
- (2) 10% rated current to 90% rated current
- (3) Under sense mode
- (4) Voltage rise time from 10% to 90% of rated voltage and voltage fall time from 90% to 10% of rated voltage

IT27334R

Model	IT27334R Bidirectional DC power supply	
Rated value	Voltage	0~30V

	Current	-15A~15A
	Power	-200W~200W
	Series internal resistance (CV Priority)	0~1Ω
	Load internal resistance (CC Priority)	0.02Ω~200Ω
	MOV (Sink mode)	0.3V at 15A
Setup Resolution	Voltage	0.001V
	Current	0.001A
	Power	0.01W
	Series internal resistance (CV Priority)	0.0001Ω
	Load internal resistance (CC Priority)	0.01Ω
Read Back Resolution	Voltage	0.0001V
	Current	0.0001A
	Power	0.01W
Setup Accuracy	Voltage	$\leq 0.02\% + 0.02\%FS$
	Current	$\leq 0.05\% + 0.05\%FS$
	Power	$\leq 0.1\% + 0.2\%FS$
	Series internal resistance (CV Priority)	$\leq 1\%FS$
	Load internal resistance (CC Priority) ⁽¹⁾	$(V_{in}/R_{set}) * 0.5\% + 0.5\%FS$
Read Back Accuracy	Voltage	$\leq 0.02\% + 0.02\%FS$
	Current	$\leq 0.05\% + 0.05\%FS$
	Power	$\leq 0.1\% + 0.2\%FS$
Voltage ripple ⁽²⁾	V _{peak}	$\leq 30mV_{pp}$
	V _{rms}	$\leq 5mV$
Setup Temperature Coefficient	Voltage	$\leq 20ppm/^{\circ}C$
	Current	$\leq 30ppm/^{\circ}C$
Read Back Temperature Coefficient	Voltage	$\leq 20ppm/^{\circ}C$
	Current	$\leq 30ppm/^{\circ}C$

Rise Time(no load)	Voltage	≤10ms
Rise Time(full load)	Voltage	≤20ms
Fall Time(no load)	Voltage	≤10ms
Fall Time(full load)	Voltage	≤10ms
Transient Response Time ⁽³⁾	Voltage	≤1ms
Line Regulation	Voltage	≤0.005% + 0.005%FS
	Current	≤0.015% + 0.015%FS
Load Regulation	Voltage ⁽⁴⁾	≤0.005% + 0.005%FS
	Current	≤0.015% + 0.015%FS
Output protection	OCP	-15.3A or 15.3A
	OVP	30.6V
	OPP	-204W or 204W
Remote Sense Compensation Voltage	≤3V	
Isolation DC to GND	800Vdc	
Working Temperature	0~40℃	
Storage Temperature	-10℃~70℃	
IP	IP20	
Cooling	Air	
Dimension (mm)	320mm*50mm*40mm	
Weight(net)	0.6kg	

Note:

- (1) The voltage/current input is no less than 10%FS.
- (2) Ripple peak and RMS doubled for voltages 0.5V and below
- (3) 10% rated current to 90% rated current
- (4) Under sense mode
- (5) Voltage rise time from 10% to 90% of rated voltage and voltage fall time from 90% to 10% of rated voltage

IT27335R

Model	IT27335R Bidirectional DC power supply
-------	--

Rated value	Voltage	0~60V
	Current	-10A~10A
	Power	-200W~200W
	Series internal resistance (CV Priority)	0~1Ω
	Load internal resistance (CC Priority)	0.06Ω~600Ω
	Min. operating voltage (Sink mode)	0.6V at 10A
Setup Resolution	Voltage	0.001V
	Current	0.001A
	Power	0.01W
	Series internal resistance (CV Priority)	0.0001Ω
	Load internal resistance (CC Priority)	0.01Ω
Read Back Resolution	Voltage	0.0001V
	Current	0.0001A
	Power	0.01W
Setup Accuracy	Voltage	$\leq 0.02\% + 0.02\%FS$
	Current	$\leq 0.05\% + 0.05\%FS$
	Power	$\leq 0.1\% + 0.2\%FS$
	Series internal resistance (CV Priority)	$\leq 1\%FS$
	Load internal resistance (CC Priority) ⁽¹⁾	$(V_{in}/R_{set}) * 0.5\% + 0.5\%FS$
Read Back Accuracy	Voltage	$\leq 0.02\% + 0.02\%FS$
	Current	$\leq 0.05\% + 0.05\%FS$
	Power	$\leq 0.1\% + 0.2\%FS$
Voltage ripple ⁽²⁾	V _{peak}	$\leq 60mV_{pp}$
	V _{rms}	$\leq 10mV$
Setup Temperature Coefficient	Voltage	$\leq 20ppm/^{\circ}C$
	Current	$\leq 30ppm/^{\circ}C$
Read Back Temperature Coefficient	Voltage	$\leq 20ppm/^{\circ}C$

	Current	$\leq 30\text{ppm}/^{\circ}\text{C}$
Rise Time(no load)	Voltage	$\leq 10\text{ms}$
Rise Time(full load)	Voltage	$\leq 20\text{ms}$
Fall Time(no load)	Voltage	$\leq 10\text{ms}$
Fall Time(full load)	Voltage	$\leq 10\text{ms}$
Transient Response Time ⁽³⁾	Voltage	$\leq 1\text{ms}$
Line Regulation	Voltage	$\leq 0.005\% + 0.005\%\text{FS}$
	Current	$\leq 0.015\% + 0.015\%\text{FS}$
Load Regulation	Voltage ⁽⁴⁾	$\leq 0.005\% + 0.005\%\text{FS}$
	Current	$\leq 0.015\% + 0.015\%\text{FS}$
Output protection	OCP	-10.2A or 10.2A
	OVP	61.2V
	OPP	-204W or 204W
Remote Sense Compensation Voltage	$\leq 6\text{V}$	
Isolation DC to GND	800Vdc	
Working Temperature	0~40°C	
Storage Temperature	-10°C~70°C	
IP	IP20	
Cooling	Air	
Dimension (mm)	320mm*50mm*40mm	
Weight(net)	0.6kg	

Note:

- (1) The voltage/current input is no less than 10%FS.
- (2) Ripple peak and RMS doubled for voltages 0.5V and below
- (3) 10% rated current to 90% rated current
- (4) Under sense mode
- (5) Voltage rise time from 10% to 90% of rated voltage and voltage fall time from 90% to 10% of rated voltage

IT27337R

Model	IT27337R Bidirectional DC power supply	
Rated value	Voltage	0~150V
	Current	-5A~5A
	Power	-200W~200W
	Series internal resistance (CV Priority)	0~1Ω
	Load internal resistance (CC Priority)	0.3Ω~3000Ω
	Min. operating voltage (Sink mode)	1.5V at 5A
Setup Resolution	Voltage	0.01V
	Current	0.001A
	Power	0.01W
	Series internal resistance (CV Priority)	0.0001Ω
	Load internal resistance (CC Priority)	0.01Ω
Read Back Resolution	Voltage	0.0001V
	Current	0.0001A
	Power	0.01W
Setup Accuracy	Voltage	≤0.02% + 0.02%FS
	Current	≤0.05% + 0.05%FS
	Power	≤0.1% + 0.2%FS
	Series internal resistance (CV Priority)	≤1%FS
	Load internal resistance (CC Priority) ⁽¹⁾	(Vin/Rset)*0.5%+0.5%FS
Read Back Accuracy	Voltage	≤0.02% + 0.02%FS
	Current	≤0.05% + 0.05%FS
	Power	≤0.1% + 0.2%FS
Voltage ripple ⁽²⁾	V _{peak}	≤150mV _{pp}
	V _{rms}	≤30mV
Setup Temperature Coefficient	Voltage	≤20ppm/°C
	Current	≤30ppm/°C

Read Back Temperature Coefficient	Voltage	$\leq 20\text{ppm}/^{\circ}\text{C}$
	Current	$\leq 30\text{ppm}/^{\circ}\text{C}$
Rise Time(no load)	Voltage	$\leq 10\text{ms}$
Rise Time(full load)	Voltage	$\leq 20\text{ms}$
Fall Time(no load)	Voltage	$\leq 10\text{ms}$
Fall Time(full load)	Voltage	$\leq 10\text{ms}$
Transient Response Time ⁽³⁾	Voltage	$\leq 1\text{ms}$
Line Regulation	Voltage	$\leq 0.005\% + 0.005\%\text{FS}$
	Current	$\leq 0.015\% + 0.015\%\text{FS}$
Load Regulation	Voltage ⁽⁴⁾	$\leq 0.005\% + 0.005\%\text{FS}$
	Current	$\leq 0.015\% + 0.015\%\text{FS}$
Output protection	OCP	-5.1A or 5.1A
	OVP	153V
	OPP	-204W or 204W
Remote Sense Compensation Voltage	$\leq 15\text{V}$	
Isolation DC to GND	800Vdc	
Working Temperature	0~40°C	
Storage Temperature	-10°C~70°C	
IP	IP20	
Cooling	Air	
Dimension (mm)	320mm*50mm*40mm	
Weight(net)	0.6kg	

Note:

- (1) The voltage/current input is no less than 10%FS.
- (2) Ripple peak and RMS doubled for voltages 0.5V and below
- (3) 10% rated current to 90% rated current
- (4) Under sense mode
- (5) Voltage rise time from 10% to 90% of rated voltage and voltage fall time from 90% to 10% of rated voltage

IT27354R

Model	IT27354R Bidirectional DC power supply	
Rated value	Voltage	0~30V
	Current	-30A~30A
	Power	-500W~500W
	Series internal resistance (CV Priority)	0~1Ω
	Load internal resistance (CC Priority)	0.01Ω~100Ω
	Min. operating voltage (Sink mode)	0.3V at 30A
Setup Resolution	Voltage	0.001V
	Current	0.001A
	Power	0.01W
	Series internal resistance (CV Priority)	0.0001Ω
	Load internal resistance (CC Priority)	0.01Ω
Read Back Resolution	Voltage	0.0001V
	Current	0.0001A
	Power	0.01W
Setup Accuracy	Voltage	≤0.02% + 0.02%FS
	Current	≤0.05% + 0.05%FS
	Power	≤0.1% + 0.2%FS
	Series internal resistance (CV Priority)	≤1%FS
	Load internal resistance (CC Priority) ⁽¹⁾	(Vin/Rset)*0.5%+0.5%FS
Read Back Accuracy	Voltage	≤0.02% + 0.02%FS
	Current	≤0.05% + 0.05%FS
	Power	≤0.1% + 0.2%FS
Voltage ripple ⁽²⁾	Vpeak	≤30mVpp
	Vrms	≤5mV
Setup Temperature Coefficient	Voltage	≤20ppm/°C
	Current	≤30ppm/°C

Read Back Temperature Coefficient	Voltage	$\leq 20\text{ppm}/^{\circ}\text{C}$
	Current	$\leq 30\text{ppm}/^{\circ}\text{C}$
Rise Time(no load)	Voltage	$\leq 10\text{ms}$
Rise Time(full load)	Voltage	$\leq 20\text{ms}$
Fall Time(no load)	Voltage	$\leq 10\text{ms}$
Fall Time(full load)	Voltage	$\leq 10\text{ms}$
Transient Response Time ⁽³⁾	Voltage	$\leq 1\text{ms}$
Line Regulation	Voltage	$\leq 0.005\% + 0.005\%\text{FS}$
	Current	$\leq 0.015\% + 0.015\%\text{FS}$
Load Regulation	Voltage ⁽⁴⁾	$\leq 0.005\% + 0.005\%\text{FS}$
	Current	$\leq 0.015\% + 0.015\%\text{FS}$
Output protection	OCP	-30.6A or 30.6A
	OVP	30.6V
	OPP	-510W or 510W
Remote Sense Compensation Voltage	$\leq 3\text{V}$	
Isolation DC to GND	800Vdc	
Working Temperature	0~40°C	
Storage Temperature	-10°C~70°C	
IP	IP20	
Cooling	Air	
Dimension (mm)	320mm*100mm*40mm	
Weight(net)	1.0kg	

Note:

- (1) The voltage/current input is no less than 10%FS.
- (2) Ripple peak and RMS doubled for voltages 0.5V and below
- (3) 10% rated current to 90% rated current
- (4) Under sense mode
- (5) Voltage rise time from 10% to 90% of rated voltage and voltage fall time from 90% to 10% of rated voltage

IT27355R

Model	IT27355R Bidirectional DC power supply	
Rated value	Voltage	0~60V
	Current	-20A~20A
	Power	-500W~500W
	Series internal resistance (CV Priority)	0~1Ω
	Load internal resistance (CC Priority)	0.03Ω~300Ω
	Min. operating voltage (Sink mode)	0.6V at 20A
Setup Resolution	Voltage	0.001V
	Current	0.001A
	Power	0.01W
	Series internal resistance (CV Priority)	0.0001Ω
	Load internal resistance (CC Priority)	0.01Ω
Read Back Resolution	Voltage	0.0001V
	Current	0.0001A
	Power	0.01W
Setup Accuracy	Voltage	≤0.02% + 0.02%FS
	Current	≤0.05% + 0.05%FS
	Power	≤0.1% + 0.2%FS
	Series internal resistance (CV Priority)	≤1%FS
	Load internal resistance (CC Priority) ⁽¹⁾	(Vin/Rset)*0.5%+0.5%FS
Read Back Accuracy	Voltage	≤0.02% + 0.02%FS
	Current	≤0.05% + 0.05%FS
	Power	≤0.1% + 0.2%FS
Voltage ripple ⁽²⁾	V _{peak}	≤60mV _{pp}
	V _{rms}	≤10mV
Setup Temperature Coefficient	Voltage	≤20ppm/°C
	Current	≤30ppm/°C

Read Back Temperature Coefficient	Voltage	$\leq 20\text{ppm}/^{\circ}\text{C}$
	Current	$\leq 30\text{ppm}/^{\circ}\text{C}$
Rise Time(no load)	Voltage	$\leq 10\text{ms}$
Rise Time(full load)	Voltage	$\leq 20\text{ms}$
Fall Time(no load)	Voltage	$\leq 10\text{ms}$
Fall Time(full load)	Voltage	$\leq 10\text{ms}$
Transient Response Time ⁽³⁾	Voltage	$\leq 1\text{ms}$
Line Regulation	Voltage	$\leq 0.005\% + 0.005\%\text{FS}$
	Current	$\leq 0.015\% + 0.015\%\text{FS}$
Load Regulation	Voltage ⁽⁴⁾	$\leq 0.005\% + 0.005\%\text{FS}$
	Current	$\leq 0.015\% + 0.015\%\text{FS}$
Output protection	OCP	-20.4A or 20.4A
	OVP	61.2V
	OPP	-510W or 510W
Remote Sense Compensation Voltage	$\leq 6\text{V}$	
Isolation DC to GND	800Vdc	
Working Temperature	0~40°C	
Storage Temperature	-10°C~70°C	
IP	IP20	
Cooling	Air	
Dimension (mm)	320mm*100mm*40mm	
Weight(net)	1.0kg	

Note:

- (1) The voltage/current input is no less than 10%FS.
- (2) Ripple peak and RMS doubled for voltages 0.5V and below
- (3) 10% rated current to 90% rated current
- (4) Under sense mode
- (5) Voltage rise time from 10% to 90% of rated voltage and voltage fall time from 90% to 10% of rated voltage

IT27357R

Model	IT27357R Bidirectional DC power supply	
Rated value	Voltage	0~150V
	Current	-10A~10A
	Power	-500W~500W
	Series internal resistance (CV Priority)	0~1Ω
	Load internal resistance (CC Priority)	0.15Ω~1500Ω
	Min. operating voltage (Sink mode)	1.5V at 10A
Setup Resolution	Voltage	0.01V
	Current	0.001A
	Power	0.01W
	Series internal resistance (CV Priority)	0.0001Ω
	Load internal resistance (CC Priority)	0.01Ω
Read Back Resolution	Voltage	0.0001V
	Current	0.0001A
	Power	0.01W
Setup Accuracy	Voltage	≤0.02% + 0.02%FS
	Current	≤0.05% + 0.05%FS
	Power	≤0.1% + 0.2%FS
	Series internal resistance (CV Priority)	≤1%FS
	Load internal resistance (CC Priority) ⁽¹⁾	(Vin/Rset)*0.5%+0.5%FS
Read Back Accuracy	Voltage	≤0.02% + 0.02%FS
	Current	≤0.05% + 0.05%FS
	Power	≤0.1% + 0.2%FS
Voltage ripple ⁽²⁾	Vpeak	≤150mVpp
	Vrms	≤30mV
Setup Temperature Coefficient	Voltage	≤20ppm/°C
	Current	≤30ppm/°C

Read Back Temperature Coefficient	Voltage	$\leq 20\text{ppm}/^{\circ}\text{C}$
	Current	$\leq 30\text{ppm}/^{\circ}\text{C}$
Rise Time(no load)	Voltage	$\leq 10\text{ms}$
Rise Time(full load)	Voltage	$\leq 20\text{ms}$
Fall Time(no load)	Voltage	$\leq 10\text{ms}$
Fall Time(full load)	Voltage	$\leq 10\text{ms}$
Transient Response Time ⁽³⁾	Voltage	$\leq 1\text{ms}$
Line Regulation	Voltage	$\leq 0.005\% + 0.005\%\text{FS}$
	Current	$\leq 0.015\% + 0.015\%\text{FS}$
Load Regulation	Voltage ⁽⁴⁾	$\leq 0.005\% + 0.005\%\text{FS}$
	Current	$\leq 0.015\% + 0.015\%\text{FS}$
Output protection	OCP	-10.2A or 10.2A
	OVP	153V
	OPP	-510W or 510W
Remote Sense Compensation Voltage	$\leq 15\text{V}$	
Isolation DC to GND	800Vdc	
Working Temperature	0~40°C	
Storage Temperature	-10°C~70°C	
IP	IP20	
Cooling	Air	
Dimension (mm)	320mm*100mm*40mm	
Weight(net)	1.0kg	

Note:

- (1) The voltage/current input is no less than 10%FS.
- (2) Ripple peak and RMS doubled for voltages 0.5V and below
- (3) 10% rated current to 90% rated current
- (4) Under sense mode
- (5) Voltage rise time from 10% to 90% of rated voltage and voltage fall time from 90% to 10% of rated voltage

IT27534R

Model	IT27534R Programmable DC Load	
Rated value	Voltage	0.03V~30V
	Current	0~15A
	Power	0~200W
	Resistance	0.02Ω~200Ω
	Min. operating voltage	0.3V at 15A
	Input leakage current	0.001A
Setup Resolution	Voltage	0.001V
	Current	0.001A
	Power	0.01W
	Resistance	0.01Ω
Read Back Resolution	Voltage	0.0001V
	Current	0.0001A
	Power	0.01W
Setup Accuracy	Voltage	≤0.02% + 0.02%FS
	Current	≤0.05% + 0.05%FS
	Power	≤0.1% + 0.2%FS
	Resistance ⁽¹⁾	(Vin/Rset)*0.5%+0.5%FS
Read Back Accuracy	Voltage	≤0.02% + 0.02%FS
	Current	≤0.05% + 0.05%FS
	Power	≤0.1% + 0.2%FS
Setup Temperature Coefficient	Voltage	≤20ppm/°C
	Current	≤30ppm/°C
Read Back Temperature Coefficient	Voltage	≤20ppm/°C
	Current	≤30ppm/°C
Current Slope	Rising slope	15A/ms
	Falling slope	15A/ms
Line Regulation	Voltage	≤0.005% + 0.005%FS
	Current	≤0.015% + 0.015%FS
Load Regulation	Voltage ⁽²⁾	≤0.005% + 0.005%FS
	Current	≤0.015% + 0.015%FS
Isc	Current	15.75A
Input protection	OCP	15.3A
	OVP	30.6V

	OPP	204W
Input OVP	31.5V	
Remote Sense Compensation Voltage	≤3V	
Isolation DC to GND	800Vdc	
Working Temperature	0~40°C	
Storage Temperature	-10°C~70°C	
IP	IP20	
Cooling	Air	
Dimension (mm)	320mm*50mm*40mm	
Weight(net)	0.6kg	

Note:

- (1) The voltage/current input is not less than 10%FS.
- (2) Under sense mode

IT27535R

Model	IT27535R Programmable DC Load	
Rated value	Voltage	0.06V~60V
	Current	0~10A
	Power	0~200W
	Resistance	0.06Ω~600Ω
	Min. operating voltage	0.6V at 10A
	Input leakage current	0.001A
Setup Resolution	Voltage	0.001V
	Current	0.001A
	Power	0.01W
	Resistance	0.01Ω
Read Back Resolution	Voltage	0.0001V
	Current	0.0001A
	Power	0.01W
Setup Accuracy	Voltage	≤0.02% + 0.02%FS
	Current	≤0.05% + 0.05%FS
	Power	≤0.1% + 0.2%FS
	Resistance ⁽¹⁾	(Vin/Rset)*0.5%+0.5%FS
Read Back Accuracy	Voltage	≤0.02% + 0.02%FS

	Current	$\leq 0.05\% + 0.05\%FS$
	Power	$\leq 0.1\% + 0.2\%FS$
Setup Temperature Coefficient	Voltage	$\leq 20\text{ppm}/^\circ\text{C}$
	Current	$\leq 30\text{ppm}/^\circ\text{C}$
Read Back Temperature Coefficient	Voltage	$\leq 20\text{ppm}/^\circ\text{C}$
	Current	$\leq 30\text{ppm}/^\circ\text{C}$
Current Slope	Rising slope	10A/ms
	Falling slope	10A/ms
Line Regulation	Voltage	$\leq 0.005\% + 0.005\%FS$
	Current	$\leq 0.015\% + 0.015\%FS$
Load Regulation	Voltage ⁽²⁾	$\leq 0.005\% + 0.005\%FS$
	Current	$\leq 0.015\% + 0.015\%FS$
Isc	Current	10.5A
Input protection	OCP	10.2A
	OVP	61.2V
	OPP	204W
Input OVP	63V	
Remote Sense Compensation Voltage	$\leq 6V$	
Isolation DC to GND	800Vdc	
Working Temperature	0~40°C	
Storage Temperature	-10°C~70°C	
IP	IP20	
Cooling	Air	
Dimension (mm)	320mm*50mm*40mm	
Weight(net)	0.6kg	

Note:

- (1) The voltage/current input is not less than 10%FS.
- (2) Under sense mode

IT27537R

Model	IT27537R Programmable DC Load	
Rated value	Voltage	0.150V~150V
	Current	0~5A
	Power	0~200W
	Resistance	0.3Ω~3000Ω

	Min. operating voltage	1.5V at 5A
	Input leakage current	0.001A
Setup Resolution	Voltage	0.01V
	Current	0.001A
	Power	0.01W
	Resistance	0.01Ω
Read Back Resolution	Voltage	0.0001V
	Current	0.0001A
	Power	0.01W
Setup Accuracy	Voltage	$\leq 0.02\% + 0.02\%FS$
	Current	$\leq 0.05\% + 0.05\%FS$
	Power	$\leq 0.1\% + 0.2\%FS$
	Resistance ⁽¹⁾	$(V_{in}/R_{set}) * 0.5\% + 0.5\%FS$
Read Back Accuracy	Voltage	$\leq 0.02\% + 0.02\%FS$
	Current	$\leq 0.05\% + 0.05\%FS$
	Power	$\leq 0.1\% + 0.2\%FS$
Setup Temperature Coefficient	Voltage	$\leq 20ppm/^{\circ}C$
	Current	$\leq 30ppm/^{\circ}C$
Read Back Temperature Coefficient	Voltage	$\leq 20ppm/^{\circ}C$
	Current	$\leq 30ppm/^{\circ}C$
Current Slope	Rising slope	5A/ms
	Falling slope	5A/ms
Line Regulation	Voltage	$\leq 0.005\% + 0.005\%FS$
	Current	$\leq 0.015\% + 0.015\%FS$
Load Regulation	Voltage ⁽²⁾	$\leq 0.005\% + 0.005\%FS$
	Current	$\leq 0.015\% + 0.015\%FS$
Isc	Current	5.25A
Input protection	OCP	5.1A

	OVP	153V
	OPP	204W
Input OVP	156V	
Remote Sense Compensation Voltage	≤15V	
Isolation DC to GND	800Vdc	
Working Temperature	0~40℃	
Storage Temperature	-10℃~70℃	
IP	IP20	
Cooling	Air	
Dimension (mm)	320mm*50mm*40mm	
Weight(net)	0.6kg	

Note:

- (1) The voltage/current input is not less than 10%FS.
- (2) Under sense mode

IT27554R

Model	IT27554R Programmable DC Load	
Rated value	Voltage	0.03V~30V
	Current	0~30A
	Power	0~500W
	Resistance	0.01Ω~100Ω
	Min. operating voltage	0.3V at 30A
	Input leakage current	0.001A
Setup Resolution	Voltage	0.001V
	Current	0.001A
	Power	0.01W
	Resistance	0.01Ω
Read Back	Voltage	0.0001V

Resolution	Current	0.0001A
	Power	0.01W
Setup Accuracy	Voltage	$\leq 0.02\% + 0.02\%FS$
	Current	$\leq 0.05\% + 0.05\%FS$
	Power	$\leq 0.1\% + 0.2\%FS$
	Resistance ⁽¹⁾	$(V_{in}/R_{set}) * 0.5\% + 0.5\%FS$
Read Back Accuracy	Voltage	$\leq 0.02\% + 0.02\%FS$
	Current	$\leq 0.05\% + 0.05\%FS$
	Power	$\leq 0.1\% + 0.2\%FS$
Setup Temperature Coefficient	Voltage	$\leq 20ppm/^{\circ}C$
	Current	$\leq 30ppm/^{\circ}C$
Read Back Temperature Coefficient	Voltage	$\leq 20ppm/^{\circ}C$
	Current	$\leq 30ppm/^{\circ}C$
Current Slope	Rising slope	30A/ms
	Falling slope	30A/ms
Line Regulation	Voltage	$\leq 0.005\% + 0.005\%FS$
	Current	$\leq 0.015\% + 0.015\%FS$
Load Regulation	Voltage ⁽²⁾	$\leq 0.005\% + 0.005\%FS$
	Current	$\leq 0.015\% + 0.015\%FS$
Isc	Current	31.5A
Input protection	OCP	30.6A
	OVP	30.6V
	OPP	510W
Input OVP	31.5V	
Remote Sense Compensation Voltage	$\leq 3V$	
Isolation DC to GND	800Vdc	
Working Temperature	0~40°C	
Storage Temperature	-10°C~70°C	

IP	IP20
Cooling	Air
Dimension (mm)	320mm*100mm*40mm
Weight(net)	1.0kg

Note:

- (1) The voltage/current input is not less than 10%FS.
- (2) Under sense mode

IT27555R

Model	IT27555R Programmable DC Load	
Rated value	Voltage	0.06V~60V
	Current	0~20A
	Power	0~500W
	Resistance	0.03Ω~300Ω
	Min. operating voltage	0.6V at 20A
	Input leakage current	0.001A
Setup Resolution	Voltage	0.001V
	Current	0.001A
	Power	0.01W
	Resistance	0.01Ω
Read Back Resolution	Voltage	0.0001V
	Current	0.0001A
	Power	0.01W
Setup Accuracy	Voltage	≤0.02% + 0.02%FS
	Current	≤0.05% + 0.05%FS
	Power	≤0.1% + 0.2%FS
	Resistance ⁽¹⁾	(Vin/Rset)*0.5%+0.5%FS
Read Back Accuracy	Voltage	≤0.02% + 0.02%FS
	Current	≤0.05% + 0.05%FS
	Power	≤0.1% + 0.2%FS

Setup Temperature Coefficient	Voltage	$\leq 20\text{ppm}/^{\circ}\text{C}$
	Current	$\leq 30\text{ppm}/^{\circ}\text{C}$
Read Back Temperature Coefficient	Voltage	$\leq 20\text{ppm}/^{\circ}\text{C}$
	Current	$\leq 30\text{ppm}/^{\circ}\text{C}$
Current Slope	Rising slope	20A/ms
	Falling slope	20A/ms
Line Regulation	Voltage	$\leq 0.005\% + 0.005\%\text{FS}$
	Current	$\leq 0.015\% + 0.015\%\text{FS}$
Load Regulation	Voltage ⁽²⁾	$\leq 0.005\% + 0.005\%\text{FS}$
	Current	$\leq 0.015\% + 0.015\%\text{FS}$
Isc	Current	21.0A
Input protection	OCP	15.3A
	OVP	61.2V
	OPP	510W
Input OVP	63V	
Remote Sense Compensation Voltage	$\leq 6\text{V}$	
Isolation DC to GND	800Vdc	
Working Temperature	0~40°C	
Storage Temperature	-10°C ~ 70°C	
IP	IP20	
Cooling	Air	
Dimension (mm)	320mm*100mm*40mm	
Weight(net)	1.0kg	

Note:

- (1) The voltage/current input is not less than 10%FS.
- (2) Under sense mode

IT27557R

Model	IT27557R Programmable DC Load	
Rated value	Voltage	0.150V~150V
	Current	0~10A
	Power	0~500W
	Resistance	0.15Ω~1500Ω
	Min. operating voltage	1.5V at 10A
	Input leakage current	0.001A
Setup Resolution	Voltage	0.01V
	Current	0.001A
	Power	0.01W
	Resistance	0.01Ω
Read Back Resolution	Voltage	0.0001V
	Current	0.0001A
	Power	0.01W
Setup Accuracy	Voltage	≤0.02% + 0.02%FS
	Current	≤0.05% + 0.05%FS
	Power	≤0.1% + 0.2%FS
	Resistance ⁽¹⁾	(Vin/Rset)*0.5%+0.5%FS
Read Back Accuracy	Voltage	≤0.02% + 0.02%FS
	Current	≤0.05% + 0.05%FS
	Power	≤0.1% + 0.2%FS
Setup Temperature Coefficient	Voltage	≤20ppm/°C
	Current	≤30ppm/°C
Read Back Temperature Coefficient	Voltage	≤20ppm/°C
	Current	≤30ppm/°C
Current Slope	Rising slope	10A/ms
	Falling slope	10A/ms

Line Regulation	Voltage	$\leq 0.005\% + 0.005\%FS$
	Current	$\leq 0.015\% + 0.015\%FS$
Load Regulation	Voltage ⁽²⁾	$\leq 0.005\% + 0.005\%FS$
	Current	$\leq 0.015\% + 0.015\%FS$
Isc	Current	10.5A
Input protection	OCP	10.2A
	OVP	153V
	OPP	510W
Input OVP	156V	
Remote Sense Compensation Voltage	$\leq 15V$	
Isolation DC to GND	800Vdc	
Working Temperature	0~40°C	
Storage Temperature	-10°C~70°C	
IP	IP20	
Cooling	Air	
Dimension (mm)	320mm*100mm*40mm	
Weight(net)	1.0kg	

Note:

- (1) The voltage/current input is not less than 10%FS.
- (2) Under sense mode

Appendix

Specifications of Red and Black Test Lines

ITECH provides you with optional red and black test lines, the user can choose the company's test line for testing. For specifications of ITECH test lines and maximum current values, refer to the table below.

Model	Specifications	Length	Description
IT-E30110-AB	10A	1m	Alligator clips-Banana plugs A pair of red and black test line
IT-E30110-BB	10A	1m	Banana plugs - Banana plugs A pair of red and black test line
IT-E30110-BY	10A	1m	Banana plugs - Y-type terminals A pair of red and black test line
IT-E30312-YY	30A	1.2m	Y-type terminals - A pair of red and black test line
IT-E30320-YY	30A	2m	Y-type terminals - A pair of red and black test line
IT-E30615-OO	60A	1.5m	Ring terminals - A pair of red and black test line
IT-E31220-OO	120A	2m	Ring terminals - A pair of red and black test line
IT-E32410-OO	240A	1m	Ring terminals - A pair of red and black test line
IT-E32420-OO	240A	2m	Ring terminals - A pair of red and black test line
IT-E33620-OO	360A	2m	Ring terminals - A pair of red and black test line

For maximum current of AWG copper wire, refer to table below.

AWG	10	12	14	16	18	20	22	24	26	28
The Maximum current value(A)	40	25	20	13	10	7	5	3.5	2.5	1.7

Note: AWG (American Wire Gauge), it means X wire (marked on the wire). The table above lists current capacity of single wire at working temperature of 30°C. For reference only.



Connect with us

Thank you for purchasing ITECH products. Any questions, pls. feel free to let us know.



You can chat with us on ITECH website



For more information, pls. visit www.itechate.com



Click and follow ITECH Electronics

